

Hitachi Inverter Hoist Catalog

Hitachi Inverter Rope Hoist

Super V series (Type 4)

One- to Ten-Ton Inverter-Equipped Hoists (Pushbutton Operation)

V8 series (Type 4)

Fifteen- to Thirty-Ton Inverter-Equipped Hoists (Pushbutton Operation)

Inverter-based control

Pushbutton with 2 depressed points for changing speed

The first and second depressed points correspond to the low and high speed settings, respectively. The low and high speed settings are independent of each other and can be set to any desired speed.

Minor vibration of the suspended load

The starting and stopping impact reduction function reduces load vibrations during hoisting as well as impact on the building and crane girder.

Smooth traveling for reduced vibration of the load

The smooth acceleration and deceleration minimizes the pendular motion of the suspended load during traveling.

Reduced impacts on mechanical parts

Because the brake is applied when the motor rotation speed is low, the abrasion of the lining is reduced and so are impact on mechanical parts such as the wire ropes, sieves, couplings and gears, which means that the service lives of these parts can be prolonged.

Load sway reduction function standard

Inverter-based control reduces the pendular motion of the suspended load. However, when the load is transported, inertia causes the load to sway when the hoist operation stops.

The swaying of the suspended load can be controlled and minimized by a follow-up notch operation performed by the operator. However, this maneuver is difficult for an inexperienced operator.

The load sway reduction function standard automatically performs an operation equivalent to a follow-up notch operation, thereby minimizing the pendular motion of the load. This function eliminates the need for the operator to perform a follow-up notch operation and allows even inexperienced operators to safely and effectively operate the hoist for swift transport of the load to the intended location.

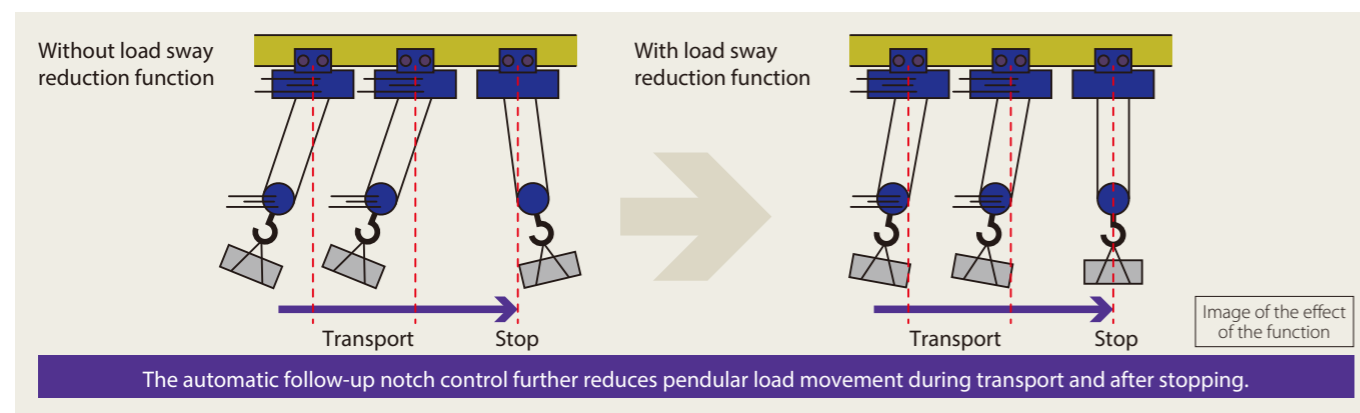

- Notes:
- This function is disabled at the factory. Refer to the Operating Manual to enable the function.
 - When the function is enabled, the load must be stationary at the time the transport operation begins. Note that the load sway reduction function may not be as effective as intended if transport begins with the load already in pendular motion.
 - When the function is enabled, the traveling speed may increase during the deceleration/stopping operation after the hoist operation is turned off. Make sure the path in which the load is moving is free of people, equipment, and parts before operating the hoist.
 - If you wish to use the load sway reduction function for the transport of the load in the traveling (saddle) direction, please use the Hitachi inverter unit for saddles (N-1C4/N-5C4 manufactured in or after October 2017).
 - Set the pushbutton to the first depressed position (low speed) to disable this function and activate the normal starting and stopping impact reduction function.
 - Disable this function when performing co-hoisting operations.

Configuring the system before using the load sway reduction function

Load sway reduction axis	Configuring the system for load sway reduction		
	Hoist	Connection cable	Saddle control panel
Traversal only	SuperV4	Not required	Not required
Traversal + travel	SuperV4	Signal cable	N-1C4 or N-5C4

* Items to be prepared by the customer
 Recommended signal cable
 Manufacture: Dyden Corporation
 Model: R080TOP-DF-SB
 Number of paired wires: 3 (6 cores)
 Core wire size: AWG20 (0.5 mm)

Inverter unit for saddles
 Note: Device manufactured no earlier than October 2017

Note: Use separate cables for the signal line and high-voltage power supply. Do not place the signal cable and high-voltage power cable within the same cable duct or cleat them together. Failure to observe this precaution may result in malfunctions or erratic operations. Keep the length of signal cables to within 40 m.

Block diagram of system in which the load sway reduction function is used for traversal and travel

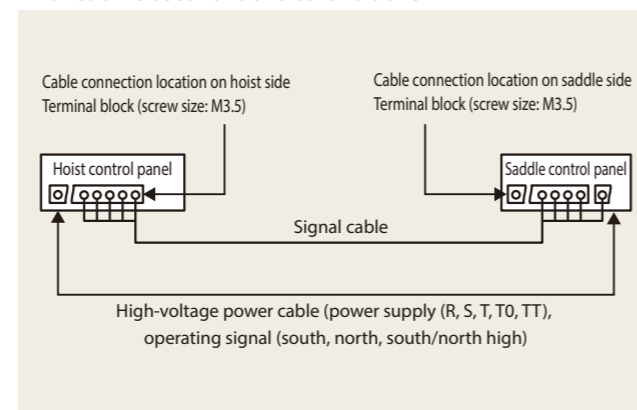

Acclaimed functions inherited from previous models.

Overloading prevention function

When hoisting is attempted of a load that is heavier than the capacity, the hoisting will be stopped automatically.

Note: The overload detection threshold may vary between 100 and 150% of the capacity depending on the operation frequency, source voltage and motor temperature.

Light-load high-speed operation function

When the hoist is operated with a light load (0% to 30% load), high-speed operation at 150% of the rated speed will automatically be selected.

- Notes:
- The maximum load determined to be a light load may vary between 30% and 40% of capacity, depending on the frequency of use, source voltage, and motor temperature.
 - Certain special high hoist lift hoists cannot be fitted with the light-load high-speed operation function. Please contact us for more information.
 - The light-load high-speed operation function cannot be used in co-hoisting operations. Please contact us for more information.

Electronic limit switch function

This function detects the hook position to allow hoisting and lowering to be stopped automatically at the set position and to reduce impact.

(The user can easily set the upper and lower limits according to his needs. The upper and lower limits are not factory-set before shipment.)

Improved ease of maintenance

Saving operational information to a USB flash drive

Operational data such as the number of times started, cumulative hours of operation, data on malfunctions, and various settings can be saved to a USB flash drive.

The data saved to the USB flash drive can be viewed on a PC to monitor and manage operating conditions.

- Notes:
- Operational data is output as text data.
 - No USB flash drive is supplied.

Load-specific operational information display function

In addition to displaying cumulative hours of operation and number of times started for each load, this function also calculates and shows the maximum rate of loading (K) recorded up to the current time power was turned on. This information is useful in planning maintenance.

Note: The load is measured and displayed based on the six categories. The displayed result may deviate from the actual load depending on the frequency of use, source voltage, and motor temperature.

Six categories: (1) No load: 0% to 10%, (2) Light load: 11% to 25%, (3) Medium load: 26% to 50%, (4) Heavy load: 51% to 75%, (5) Extra-heavy load: 76% to 100%, (6) Overload: 101% or more

Wire rope inspection assist function

In addition to displaying the total number of bending times for each 1 m segment of the wire rope and the number of bending times for each load, this function also calculates and displays the top five points (position categories) in terms of the total number of bending times.

This information can be used to inspect the locations of the wire cables that have sustained frequent bending and is useful in cable maintenance and management.

Note: The load is measured and displayed based on the six categories. The displayed result may deviate from the actual load depending on the frequency of use, source voltage, and motor temperature.

Six categories: (1) No load: 0% to 10%, (2) Light load: 11% to 25%, (3) Medium load: 26% to 50%, (4) Heavy load: 51% to 75%, (5) Extra-heavy load: 76% to 100%, (6) Overload: 101% or more

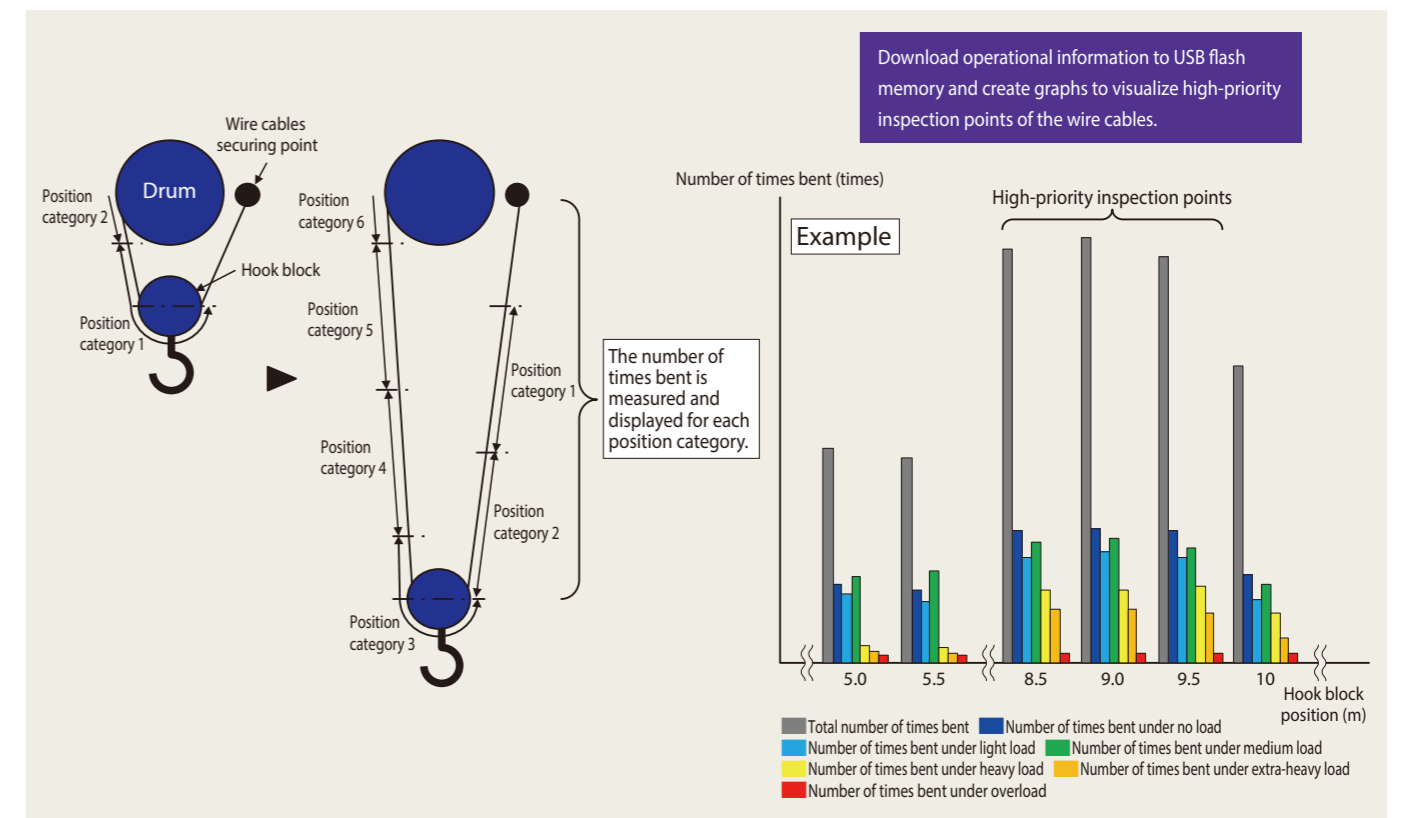

Improve ease of use

External outputs (three terminals) standard

Relays (three units) are standard to output data such as operating status. The outputs can be used for configuring a crane system.

Note: The external output terminals are not provided as part of the standard configuration in models designed for radio-based control. If you need external outputs for these models, order the optional external output function.

External inputs (five terminals) standard

Input terminals (five terminals) are standard for use in providing control based on the traverse limit input.

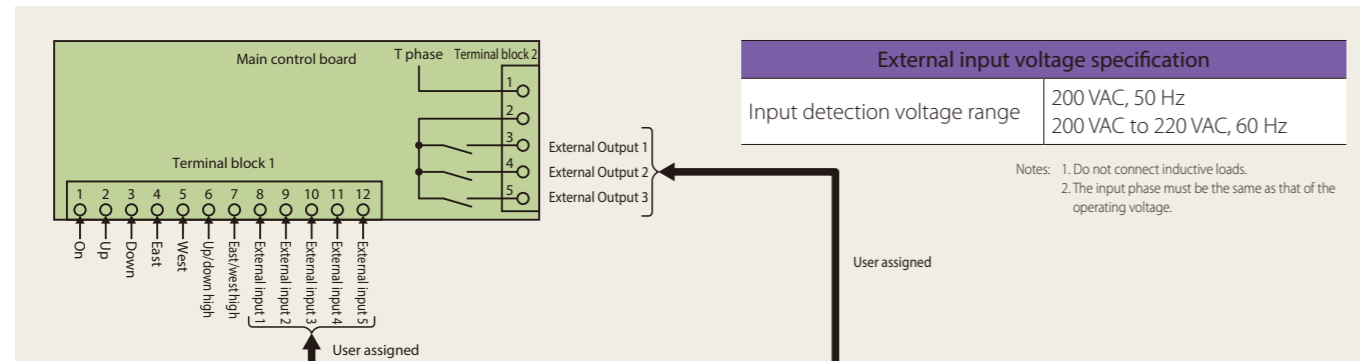

List of signals assignable to external input

No.	Input signal	Description of control provided by input
1	Hoisting operation input	Enables high-speed operation (pushbutton in second depressed position).
2	Traversal operation input	Enables high-speed operation (pushbutton in second depressed position).
3	Hoisting operation control	Disables operation or high-speed operation (pushbutton in second depressed position). (Either one of the above settings can be selected by the user.)
4	Traversal operation control	Disables operation or high-speed operation (pushbutton in second depressed position). (Either one of the above settings can be selected by the user.)
5	Disable light-load high-speed operations	Disables light-load high-speed operation.
6	Electronic limit prohibit	Disables upper-/lower-limit stopping of the electronic limit function.
7	Disable speed change point	Disables up/down speed changes in the speed change point function.
8	Hoist speed acceleration	Varies the operation speed steplessly based on input time.
9	Hoist speed deceleration	
10	Traversal speed acceleration	
11	Traversal speed deceleration	
12	Acceleration/deceleration initialization	Restores speeds changed by inputs No. 8 to No. 11 to default values.
13	Traverse limit	Controls operation based on traverse limit status.
14	Reference position setting	Resets the reference position based on input condition.
15	South operation input	Input of "south" signal
16	North operation input	Input of "north" signal
17	South/north high operation input	Input of "south/north high" signal
18	PB/radio-based control selection	Selection of use of pushbuttons on the pendant or radio-based control
19	Disable load sway reduction function	Disables control of load sway reduction function.
20	Disable lift-off operation assist function	Disables control of lift-off operation assist function.

List of signals assignable to external outputs

No.	Output signal	Signal output timing
1	Hoisting operation enabled	When hoisting operation is enabled
2	Hoisting abnormality detected	When hoisting-related abnormality is detected
3	Hoisting operation underway	When inverter frequency for hoisting is output
4	Light-load high-speed hoisting operation selected	During light-load high-speed operation
5	Hoisting overload prevention	When hoisting overload is detected
6	Electronic limit upper-limit stop	When electronic limit upper-limit stop point is reached
7	Electronic limit lower-limit stop	When electronic limit lower-limit stop point is reached
8	Up direction speed change point	When up direction speed change point is reached
9	Down direction speed change point	When down direction speed change point is reached
10	Mechanical limit 1st-stage operation	When mechanical limit 1st-stage operation is detected
11	Mechanical limit 2nd-stage operation	When mechanical limit 2nd-stage operation is detected
12	Traversal operation enabled	When traversal operation is enabled
13	Traversal abnormality detected	When traversal-related abnormality is detected
14	Traversal operation underway	When inverter frequency for traversal is output
15	Traverse limit operation	When traverse limit operation is detected
16	Operating status	When operation input is detected
17	Hook position output	When hoisting position reaches the set hoisting position
18	Maintenance alarm output	When maintenance alarm is output

Notes: 1. External inputs/outputs are not factory-set before shipment.
2. Normally Closed or Open can be selected for external outputs.
An open status results if Normally Closed is selected and no input signal is detected.

Lift-off operation assist function

This function automatically pauses the hoisting operation if a load lift-off status is detected.

This allows confirmation of the sling condition while the load is stationary, thereby enhancing safety.

Notes: 1. This control is disabled at the factory before shipment. Refer to the Operating Manual to enable the function.
2. The load value used to detect lift-off states that are 10% of the capacity or more. Note that deviations may occur due to the source voltage and motor temperature.
3. When this function is enabled, the operation is forcibly set to low speed while the lift-off status is being detected.
4. If the load is light and the lift-off status cannot be detected, the operation switches to the normal operation mode.
5. The position at which the lift-off status is detected is stored in memory and the lift-off status will not be redetected unless the load is lowered to a position below the stored position.

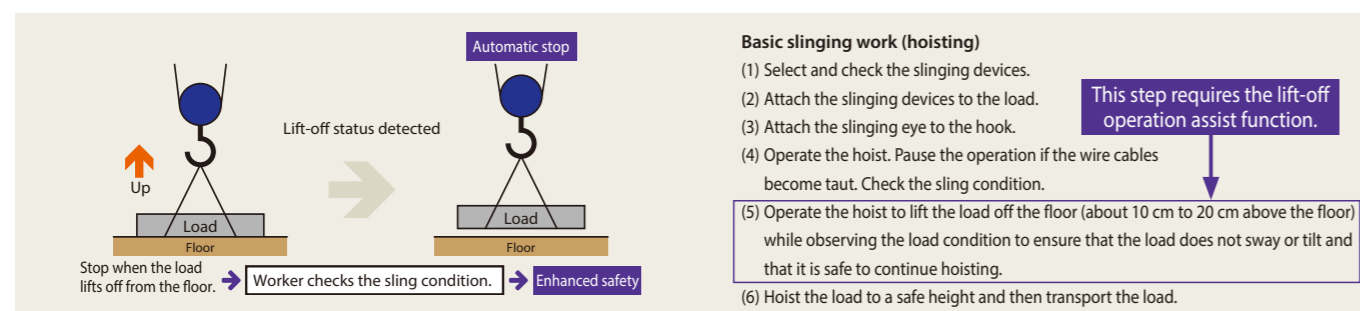

Instructions for special-order products

Co-hoisting synchronization function

This function allows the simultaneous operation of two inverter hoists using a single operating button. There are two types of co-hoisting synchronization functions: a basic function for operation synchronization and an advanced function for position synchronization.

- Operation synchronization: This is the basic synchronization function.
- Position synchronization: This function provides a basic function and an automatic hook position adjustment function. The position synchronization provides horizontal hold control and position hold control.

Item	Operation synchronization	Position synchronization
Simultaneous start/stop operation of two hoists	<input type="checkbox"/>	<input type="checkbox"/>
Simultaneous stopping of two hoists when an alarm is tripped	<input type="checkbox"/>	<input type="checkbox"/>
Simultaneous stopping of two hoists at the time of overload detection	<input type="checkbox"/>	<input type="checkbox"/>
Synchronization of light-load high-speed operations of two hoists	<input type="checkbox"/>	<input type="checkbox"/>
Correction of operation speed if the load becomes unbalanced	<input type="checkbox"/>	<input type="checkbox"/>
Automatic load position adjustment operation	<input checked="" type="checkbox"/>	<input type="checkbox"/>

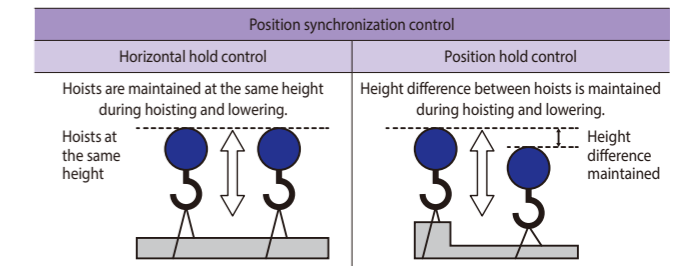

Notes: 1. Adjust the settings so that the reference points are at the same position. If high precision is required, make sure the load is level before setting the reference points. Reset periodically to maintain performance.
2. The difference in the elongation of the wire cables resulting from an offset load is not corrected automatically. The difference in motor slipping caused by an offset load is corrected automatically, but the difference in the elongation of the wire cables is not corrected. Perform slinging work carefully to ensure the appropriate balance.
3. The length of the data communication cable connecting the hoists is subject to restrictions. For position synchronization, position information is exchanged between the hoists by data communication. Use a signal cable that does not exceed 40 m in length.

Linked/Single action operation selection: linked operation or Single action operation can be selected.

Please indicate your choice when placing your order.

Pushbuttons	Selector button	Hoisting	Traversal
(Link)(Sgl)	(Link)	Two hoists operate while linked.	Two hoists operate while linked.
	(Sgl)	Only the down pushbutton is enabled.	Only the down pushbutton is enabled.
(Link)(Sgl)(Sgl A)(Sgl B)	(Link)	Two hoists operate while linked.	Two hoists operate while linked.
	(Sgl)	(Sgl A) Only the down pushbutton is enabled. (Sgl B) Hoist operations other than above	Only the down pushbutton is enabled. Hoist operations other than above

Notes: 1. The device incorporates the "Link/Sgl" feature unless otherwise specified.
2. Both the pendant pushbuttons and radio-based control pushbuttons support the co-hoisting synchronization function.
3. Please contact us if you wish to use two connected hoists.

External output function (6 points, 12 points, 18 points)

The number of output points for the external output function can be increased from the standard three points to six points, 12 points, or 18 points (selection is also possible for radio-based control).

Multispeed (hoisting: 16-speed max. + light-load high-speed, traversal: eight-speed max.)

For hoisting, up to 16 speeds can be selected by combining up/down inputs and the four speed change inputs. For traversal, up to eight speeds can be selected by combining east/west inputs and the three speed change inputs.

Speed selection	Multispeed signal input				Light-load high-speed input
	4	3	2	1	
Multispeed 1	OFF	OFF	OFF	OFF	OFF
Multispeed 2	OFF	OFF	OFF	ON	OFF
Multispeed 3	OFF	OFF	ON	OFF	OFF
Multispeed 4	OFF	OFF	ON	ON	OFF
Multispeed 5	OFF	ON	OFF	OFF	OFF
Multispeed 6	OFF	ON	OFF	ON	OFF
Multispeed 7	OFF	ON	ON	OFF	OFF
Multispeed 8	OFF	ON	ON	ON	OFF
Multispeed 9	ON	OFF	OFF	OFF	OFF
Multispeed 10	ON	OFF	OFF	ON	OFF
Multispeed 11	ON	OFF	ON	OFF	OFF
Multispeed 12	ON	OFF	ON	ON	OFF
Multispeed 13	ON	ON	OFF	OFF	OFF
Multispeed 14	ON	ON	OFF	ON	OFF
Multispeed 15	ON	ON	ON	OFF	OFF
Multispeed 16	ON	ON	ON	ON	OFF
Light-load high-speed operation input					ON

Notes: 1. Operation equipment must be provided and configured by the customer. Also, configure suitable input circuits using relays based on control equipment used.
2. In cases in which up/down operation and light-load high-speed operational inputs are ON, regardless of the multispeed signal input status, the hoist operates at the speed suitable for determining whether to activate the light-load high-speed operation. If the load is determined to be light, the hoist operates in light-load high-speed operation mode.

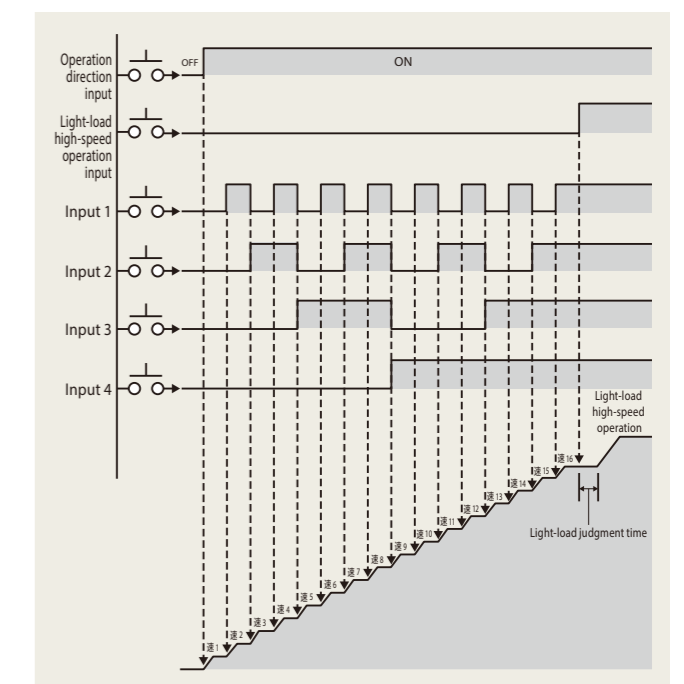

Specifications

400V Class

Series			Super V series (type4)					V8 series (type4)					
Capacity			1	2	3	5	7.5	10	15	20	30		
Hoist load			1.01	2.02	3.03	5.07	7.65	10.2	15.2	20.3	30.4		
Hoisting lift	Standard headroom type	Low hoist lift	m	6	6	6	8	8	8	8	—	—	
		High hoist lift	m	12	12	12	12	12	12	12	12	—	
	Low headroom type	Low hoist lift	m	6	6	6	6	—	—	—	—	—	
		High hoist lift	m	12	12	12	11	—	—	—	—	—	
Double-rail type	Low hoist lift	m	—	—	6	8	8	8	8	—	—		
	High hoist lift	m	—	12	12	12	12	12	12	12	12		
Hoisting Inverter	Speed (The figures in [] refer to light-load operation speeds.)		m / s	0.022 ~ 0.217[0.325]	0.017 ~ 0.167[0.25]	0.015 ~ 0.15[0.225]	0.013 ~ 0.133[0.2]	0.012 ~ 0.12[0.18]	0.01 ~ 0.10[0.15]	0.01 ~ 0.10[0.15]	0.008 ~ 0.083[0.125]	0.006 ~ 0.055[0.083]	
			m / min	1.3 ~ 13[19.5]	1.0 ~ 10[15]	0.9 ~ 9.0[13.5]	0.8 ~ 8.0[12]	0.72 ~ 7.2[10.8]	0.6 ~ 6.0[9.0]	0.6 ~ 6.0[9.0]	0.5 ~ 5.0[7.5]	0.33 ~ 3.3[5.0]	
	Motor output		kW	2.3	3.5	5.0	7.0	9.5	10.5	16	18	18	
	Rated current (200 VAC, 50 Hz/200 VAC, 60 Hz/220 VAC, 60 Hz)		A	8.0/7.0/7.0	10.5/9.5/9.5	14.0/13.0/12.0	19.0/17.0/16.0	24.0/22.0/22.0	25.0/25.0/22.0	34.0/34.5/32.0	38.0/37.0/36.0	41.0/40.0/36.0	
No. of poles of the motor			No. of poles	4	4	4	4	4	4	4	4		
Traversing Inverter	Speed		m / s	0.042 ~ 0.417	0.042 ~ 0.417	0.042 ~ 0.417	0.042 ~ 0.417	0.028 ~ 0.283	0.028 ~ 0.283	0.028 ~ 0.283	0.028 ~ 0.283	0.028 ~ 0.283	
			m / min	2.5 ~ 25	2.5 ~ 25	2.5 ~ 25	2.5 ~ 25	1.7 ~ 17	1.7 ~ 17	1.7 ~ 17	1.7 ~ 17	1.7 ~ 17	
	Standard headroom type/low headroom type	Motor output	kW	0.36	0.36	0.55	0.75	0.56 × 2	0.56 × 2	0.55 × 2	0.55 × 2	—	
		Rated current (400 VAC, 50 Hz / 400VAC, 60 Hz / 440VAC, 60 Hz)	A	0.8/0.8/0.8	0.8/0.8/0.8	1.2/1.2/1.2	1.6/1.6/1.6	1.0 × 2/1.0 × 2/1.0 × 2	1.1 × 2/1.1 × 2/1.1 × 2	1.1 × 2/1.1 × 2/1.1 × 2	1.2 × 2/1.1 × 2/1.1 × 2	—	
	Double-rail type	Motor output	kW	—	0.36	0.55	0.55	0.55 × 2	0.55 × 2	0.55 × 2	0.55 × 2	0.84 × 2	
		Rated current (400 VAC, 50 Hz / 400VAC, 60 Hz / 440VAC, 60 Hz)	A	—	0.8/0.8/0.8	1.2/1.2/1.2	1.5/1.5/1.5	1.0 × 2/1.0 × 2/1.0 × 2	1.1 × 2/1.1 × 2/1.1 × 2	1.1 × 2/1.1 × 2/1.1 × 2	1.2 × 2/1.1 × 2/1.1 × 2	1.4 × 2/1.3 × 2/1.1 × 2	
	Commercial	Speed (50Hz/60Hz)		m / s	0.35/0.417	0.35/0.417	0.35/0.417	0.35/0.417	0.233/0.283	0.233/0.283	—	—	
				m / min	21/25	21/25	21/25	21/25	14/17	14/17	—	—	
		Standard headroom type/low headroom type	Motor output (50Hz/60Hz)	kW	0.30/0.36	0.30/0.36	0.45/0.55	0.63/0.75	0.47 × 2/0.56 × 2	0.47 × 2/0.56 × 2	—	—	
			Rated current (400 VAC, 50 Hz / 400VAC, 60 Hz / 440VAC, 60 Hz)	A	1.1/1.0/1.0	1.1/1.0/1.0	1.4/1.1/1.2	1.6/1.3/1.4	2.1 × 2/1.7 × 2/1.7 × 2	2.1 × 2/1.7 × 2/1.7 × 2	—	—	
Double-rail type	Motor output (50Hz/60Hz)	kW	—	0.30/0.36	0.45/0.55	0.45/0.55	0.45 × 2/0.55 × 2	0.45 × 2/0.55 × 2	—	—			
	Rated current (400 VAC, 50 Hz / 400VAC, 60 Hz / 440VAC, 60 Hz)	A	—	1.1/1.0/1.0	1.4/1.1/1.2	1.5/1.2/1.3	1.4 × 2/1.0 × 2/1.2 × 2	1.4 × 2/1.0 × 2/1.2 × 2	—	—			
No. of poles of the motor			Standard headroom type	4	4	4	4	6	6	4	4		
			Low headroom type	4	4	4	4	—	—	—	—		
			Double-rail type	—	4	4	4	4	4	4	4		
Wire cables			Standard headroom type		No. of strands	2	2	2	4	4	4	4	
					Compositon	6 × Fi(29)-B	6 × Fi(29)-B	6 × Fi(29)-B	6 × Fi(29)-B	6 × Fi(29)-B	6 × Fi(29)-B	6 × Fi(29)-B	6 × Fi(29)-B
					Diameter (mm)	φ 8	φ 11.2	φ 14	φ 12.5	φ 14	φ 16	φ 20	φ 22.4
			Low headroom type		No. of strands	4	4	4	4	—	—	—	—
					Compositon	6 × W(19)-B	6 × Fi(29)-B	6 × Fi(29)-B	6 × Fi(29)-B	—	—	—	—
					Diameter (mm)	φ 6.3	φ 8	φ 10	φ 12.5	—	—	—	—
Double-rail type			No. of strands		—	4	4	4	4	4	4	8	
					Compositon	—	6 × Fi(29)-B	6 × Fi(29)-B	6 × Fi(29)-B	6 × Fi(29)-B	6 × Fi(29)-B	6 × Fi(29)-B	
					Diameter (mm)	—	φ 8	φ 10	φ 12.5	φ 14	φ 16	φ 20	φ 22.4
Power supply (three-phase power supply)			380VAC, 50Hz / 400VAC, 50Hz / 415VAC, 50Hz / 380VAC, 60Hz / 400VAC, 60Hz / 440VAC, 60Hz / 460VAC, 60Hz / 480VAC, 60Hz										
Operation method			Pushbuttons on the pendant Eight pushbuttons designed to be operated by an operator standing on the floor (on, off, up, down, left, right, forward and reverse) * The pushbuttons with two depressed points are as follows: Inverter-based control of hoisting and traversal: up, down, left, right, forward and reverse Inverter-based control of hoisting only: up and down Inverter-based control of traversal only: left and right										
Operating voltage			200 VAC										
Repetitive rating (rate of loading ≤ 0.63)			Hoisting	Frequency of starting	400 times per hour								
				Duty factor	40%ED								
			Traversing	Frequency of starting	400 times per hour								
				Duty factor	40%ED								
Power supply method			Power is supplied via a cable. (If you are using a collector/bus duct or other contact-type current collector, please be sure to use a double-trolley system.)										
Protection structure			JIS C0920 IP44 * For outdoor use, please provide a covered refuge bay so that the hoist is not exposed to rain. * The IP rating is for the motor section and the control panel.										
Ambient temperature			-10 to +40° C (without freezing)										
Humidity			90% or less (without condensation)										
Paint color			Munsell 2.5B, 2.5/1										
Compliance with standards			JIS C9620 (Electric Hoists), a crane structure standard										

Safety instructions for using the device

- Standard specification products cannot be used in special environments, including the ones listed below. Please contact us if you need a device that can be used in such environments.
 - Acid, alkali, and saline atmospheres; corrosive gas atmospheres
 - Environments with an ambient temperature above 40°C
 - Dusty environments
 - Environments in which the device is subject to splashing water
 - Environments with a risk of ignited explosion such as environments in which volatile dust or an organic solvent exists
 - Environments in which the device is used very frequently
- If you using the device in a place with significant power supply noises, we recommend install a noise filter. Noise can cause malfunctions, including unexpected stoppages.

- An inverter hoist will not stop immediately after you press the OFF pushbutton. The function that starts and stops the hoist to reduce impact requires a deceleration distance proportional to operating speed. Take deceleration distance when using the hoist. In particular, allow for sufficient deceleration distance when operating the hoist at high speed (above the rated speed) with the hoist carrying light load.
- If the hoist is operated continuously for more than 1 minute at the lowest speed, the inverter's overheating protection function may activate to stop the hoist. If so, allow the hoist to remain stopped until the inverter cools (usually around 5 minutes or slightly longer) before restarting the hoist.

Specifications

200V Class

Series		Super V series (type4)										V8 series (type4)			
Capacity		t	1	2	2.8	3	5	7.5	10	15	20	30			
Hoist load		t	1.01	2.02	2.83	3.03	5.07	7.65	10.2	15.2	20.3	30.4			
Hoist lift	Standard headroom type	Low hoist lift	m	6	6	6	6	8	8	8	8	—	—		
		High hoist lift	m	12	12	12	12	12	12	12	12	12	—		
	Low headroom type	Low hoist lift	m	6	6	6	6	6	—	—	—	—	—		
		High hoist lift	m	12	12	12	12	11	—	—	—	—	—		
	Double-rail type	Low hoist lift	m	—	—	6	6	8	8	8	8	—	—		
		High hoist lift	m	—	12	12	12	12	12	12	12	12	12		
Hoisting	Inverter	Speed (The figures in [] refer to light-load operation speeds.)		m/s	0.022~0.217[0.325]	0.017~0.167[0.25]	0.015~0.15[0.225]	0.015~0.15[0.225]	0.013~0.133[0.2]	0.012~0.12[0.18]	0.01~0.10[0.15]	0.01~0.10[0.15]	0.008~0.083[0.125]	0.006~0.055[0.083]	
		Motor output		kW	2.3	3.5	4.8	5.0	7.0	9.5	10.5	16	18	18	
		Rated current (200 VAC, 50 Hz/200 VAC, 60 Hz/220 VAC, 60 Hz)		A	14.0/13.5/12.5	20.0/18.0/16.0	25.0/23.0/21.0	26.0/24.0/22.0	35.0/34.0/30.0	46.0/43.0/40.0	54.0/51.0/46.0	70.0/69.0/63.0	78.0/77.0/71.0	82.0/81.0/73.0	
		No. of poles of the motor		No. of poles	4	4	4	4	4	4	4	4	4	4	
Traversing	Inverter	Speed		m/s	0.042~0.417	0.042~0.417	0.042~0.417	0.042~0.417	0.042~0.417	0.028~0.283	0.028~0.283	0.028~0.283	0.028~0.283	0.028~0.283	
		Motor output		kW	0.36	0.36	0.55	0.55	0.75	0.56×2	0.55×2	0.55×2	0.55×2	—	
		Standard headroom type/ low headroom type	Rated current (200 VAC, 50 Hz / 200VAC, 60 Hz / 220VAC, 60 Hz)		A	1.6/1.6/1.6	1.6/1.6/1.6	2.5/2.5/2.5	2.5/2.5/2.5	2.8/2.8/2.8	2.2×2/2.1×2/2.1×2	2.2×2/2.1×2/2.1×2	1.8×2/1.7×2/1.7×2	1.8×2/1.7×2/1.7×2	—
			Motor output		kW	—	0.36	0.55	0.55	0.55	0.55×2	0.55×2	0.55×2	0.55×2	0.84×2
		Double-rail type	Rated current (200 VAC, 50 Hz / 200VAC, 60 Hz / 220VAC, 60 Hz)		A	—	1.6/1.6/1.6	2.5/2.5/2.5	2.5/2.5/2.5	2.6/2.6/2.6	1.7×2/1.5×2/1.4×2	1.7×2/1.5×2/1.4×2	1.7×2/1.5×2/1.4×2	2.2×2/1.8×2/1.8×2	3.3×2/2.7×2/2.7×2
			Motor output		kW	—	0.36	0.55	0.55	0.55	0.55×2	0.55×2	0.55×2	0.55×2	0.84×2
	Commercial	Speed (50Hz/60Hz)		m/s	0.35/0.417	0.35/0.417	0.35/0.417	0.35/0.417	0.35/0.417	0.233/0.283	0.233/0.283	—	—	—	
				m/min	21/25	21/25	21/25	21/25	21/25	14/17	14/17	—	—	—	
		Standard headroom type/ low headroom type	Motor output (50Hz/60Hz)		kW	0.30/0.36	0.30/0.36	0.45/0.55	0.45/0.55	0.63/0.75	0.47×2/0.56×2	0.47×2/0.56×2	—	—	
			Rated current (200 VAC, 50 Hz / 200VAC, 60 Hz / 220VAC, 60 Hz)		A	2.0/1.6/1.8	2.0/1.6/1.8	2.7/2.0/2.3	2.7/2.0/2.3	3.0/2.3/2.6	3.7×2/2.6×2/3.0×2	3.7×2/2.6×2/3.0×2	—	—	
		Double-rail type	Motor output (50Hz/60Hz)		kW	—	0.30/0.36	0.45/0.55	0.45/0.55	0.45/0.55	0.45×2/0.55×2	0.45×2/0.55×2	—	—	
			Rated current (200 VAC, 50 Hz / 200VAC, 60 Hz / 220VAC, 60 Hz)		A	—	2.0/1.6/1.8	2.7/2.0/2.3	2.7/2.0/2.3	2.9/2.2/2.4	2.7×2/2.0×2/2.3×2	2.7×2/2.0×2/2.3×2	—	—	
Wire cables	Standard headroom type		Standard headroom type	4	4	4	4	4	6	6	4	4	—		
	Low headroom type		Low headroom type	4	4	4	4	4	—	—	—	—	—		
	Double-rail type		Double-rail type	—	4	4	4	4	4	4	4	4	4		
Common specifications	Power supply (three-phase power supply)		200V 50/60Hz, 220V 60Hz												
	Operation method		Pushbuttons on the pendant Eight pushbuttons designed to be operated by an operator standing on the floor (on, off, up, down, left, right, forward and reverse) * The pushbuttons with two depressed points are as follows: Inverter-based control of hoisting and traversal: up, down, left, right, forward and reverse Inverter-based control of hoisting only: up and down Inverter-based control of traversal only: left and right												
	Operating voltage		200 VAC or 220 VAC (depending on power supply voltage)												
	Repetitive rating (rate of loading ≤ 0.63)	Hoisting	Frequency of starting	400 times per hour											
			Duty factor	40%ED											
		Traversing	Frequency of starting	400 times per hour											
			Duty factor	40%ED											
	Power supply method		Power is supplied via a cable. (If you are using a collector/bus duct or other contact-type current collector, please be sure to use a double-trolley system.)												
	Protection structure		JIS C0920 IP44 * For outdoor use, please provide a covered refuge bay so that the hoist is not exposed to rain. * The IP rating is for the motor section and the control panel.												
	Ambient temperature		-10 to +40° C (without freezing)												
	Humidity		90% or less (without condensation)												
	Paint color		Munsell 2.5B, 2.5/1												
Compliance with standards		JIS C9620 (Electric Hoists), a crane structure standard													

Safety instructions for using the device

- Standard specification products cannot be used in special environments, including the ones listed below. Please contact us if you need a device that can be used in such environments.
 - Acid, alkali, and saline atmospheres; corrosive gas atmospheres
 - Environments with an ambient temperature above 40°C
 - Dusty environments
 - Environments in which the device is subject to splashing water
 - Environments with a risk of ignited explosion such as environments in which volatile dust or an organic solvent exists
 - Environments in which the device is used very frequently
- If you using the device in a place with significant power supply noises, we recommend install a noise filter. Noise can cause malfunctions, including unexpected stoppages.

- An inverter hoist will not stop immediately after you press the OFF pushbutton. The function that starts and stops the hoist to reduce impact requires a deceleration distance proportional to operating speed. Take deceleration distance when using the hoist. In particular, allow for sufficient deceleration distance when operating the hoist at high speed (above the rated speed) with the hoist carrying light load.
- If the hoist is operated continuously for more than 1 minute at the lowest speed, the inverter's overheating protection function may activate to stop the hoist. If so, allow the hoist to remain stopped until the inverter cools (usually around 5 minutes or slightly longer) before restarting the hoist.

Standard headroom-type hoists

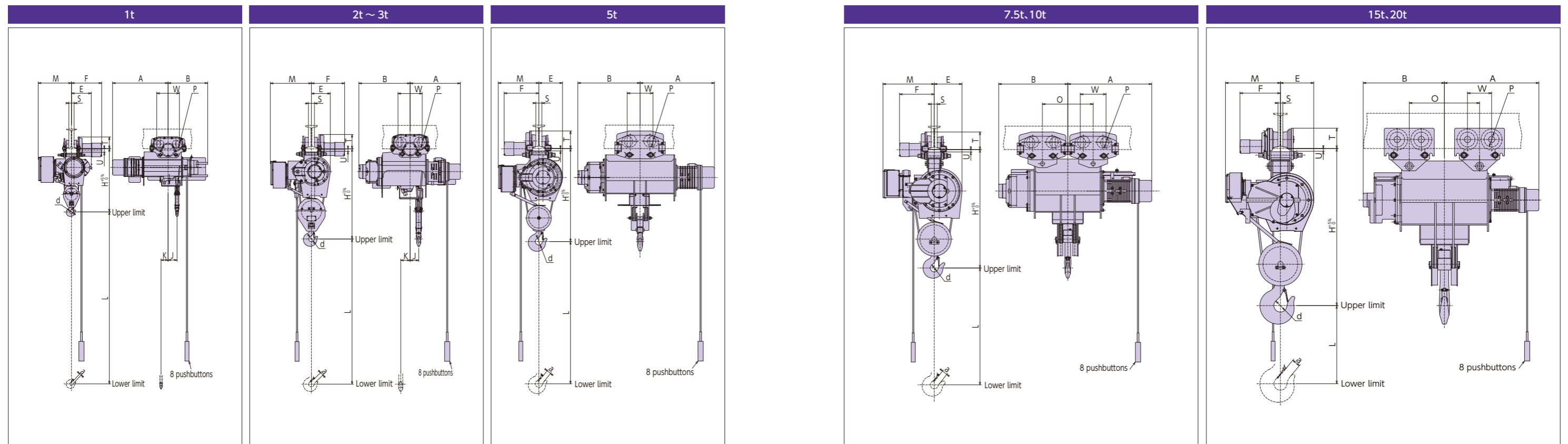

Series		Super V series (type4)												V8 series (type4)									
Type	Inverter-based control of hoisting and traversal	1M-T65-W4	1HM-T65-W4	2M-T75-W4	2HM-T75-W4	2.8M-T65-W4	2.8HM-T65-W4	3M-T65-W4	3HM-T65-W4	5M-T55-W4	5HM-T55-W4	7.5M-T55-W4	7.5HM-T55-W4	10M-T55-W4	10HM-T55-W4	15M-T88-W4	15HM-T88-W4	20HM-T88-W4					
	Inverter-based control of hoisting only	1M-T65-V4	1HM-T65-V4	2M-T75-V4	2HM-T75-V4	2.8M-T65-V4	2.8HM-T65-V4	3M-T65-V4	3HM-T65-V4	5M-T55-V4	5HM-T55-V4	7.5M-T55-V4	7.5HM-T55-V4	10M-T55-V4	10HM-T55-V4	-	-	-					
Capacity (t)		1		2		2.8		3		5		7.5		10		15		20					
Approx. dimensions (mm)	L	6,000	12,000	6,000	12,000	6,000	12,000	6,000	12,000	8,000	12,000	8,000	12,000	8,000	12,000	8,000	12,000	12,000	12,000				
	H	790		985		1,115		1,115		1,190		1,345		1,515		1,865		2,010					
	A	545	715	620	630	610	645	610	645	845	955	1,075	1,150	1,075	1,150	1,060	1,160	1,210	1,210				
	B	475	510	435	615	510	660	510	665	690	800	830	905	885	960	950	990	1,040	1,040				
	M	430		485		530		530		525		640		670		705		705					
	E	255		220		245		245		305		315		355		427		427					
	W	200/290		200/290		230/310		230/310		250/330		230/310		250/330		309/309		309/309					
	G	-		-		-		-		-		560		760		820		900					
	K	20	90	30	110	35	120	35	120	-		-		-		-		-					
	J	85	115	75	100	80	110	80	110	-		-		-		-		-					
d	45		56		71		71		90		100		100		130		165						
P	96/96		96/96		128/128		128/128		156/140		128/128		156/140		190/190		190/190						
a	23		36		42		42		58		69		69		86		108						
Min. curve radius (m)		3.5/1.5		4.5/1.8		5.0/2.0		5.0/2.0		Straight line/3.0		Straight line/Straight line		Straight line/Straight line		Straight line		Straight line					
Dimensions with respect to I-beam (mm)		F	S	T	U	F	S	T	U	F	S	T	U	F	S	T	U	F	S	T	U		
200×100×7		374	42	148	47/42	378	42	148	42/42														
250×125×7.5		387	67	151	44/39	391	67	151	39/39	417	52	177	38/38	417	52	177	38/38						
300×150×11.5		400	92	160	35/30	404	92	160	30/30	430	77	187	28/28	430	77	187	28/28						
450×175×11										443	102	185	30/30	443	102	185	30/30						
600×190×13																							
Approx. weight (kg)		200		220		295		345		405		435		405		435		710		775		970	
																		1,030		1,280		1,340	
																		2,140		2,390		2,740	

- Notes: 1. Specifications in the table are common to 200V and 400V classes.
 2. Dimensions W and P indicate [drive side/driven side].
 3. Dimension U indicates [low hoist lift/high hoist lift] ([High hoist lift] only for 20t).
 4. The min. curve radius indicates [inverter-based control of traversal/commercial traversal] ([Inverter based control of traversal] only for 15t and 20t).
 5. Unless otherwise specified by the customer, the device delivered will be compatible with I-beams with the dimensions shown in the colored columns.
 6. The device contains electronic components. Be sure to install a buffering mechanism or buffering material on the stoppers for longitudinal and traversing movement.

Double-rail-type hoists

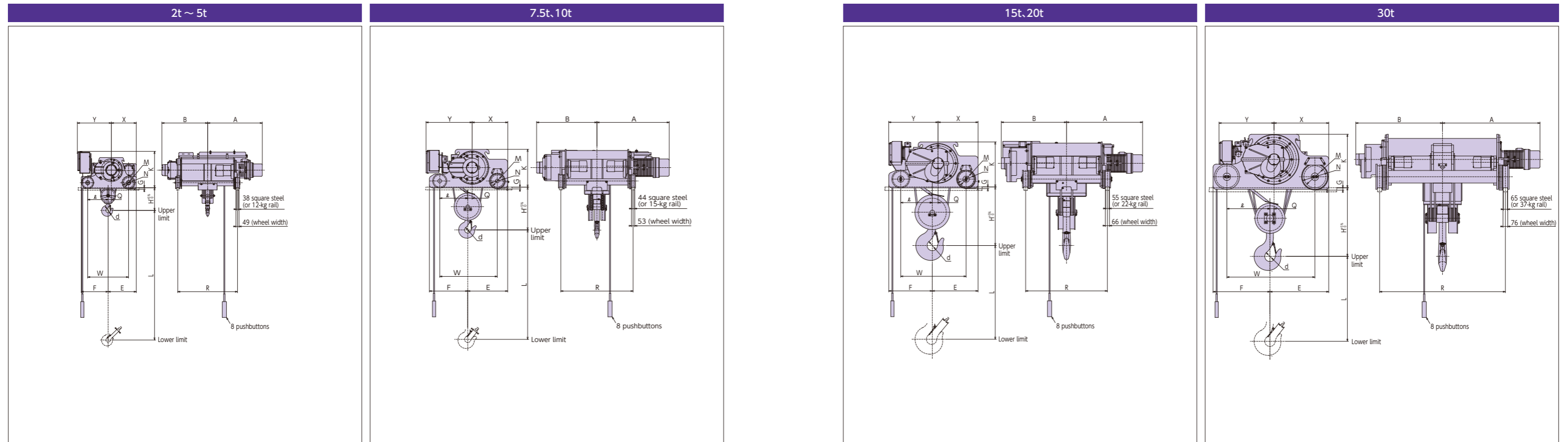

Series		Super V series (type4)										V8 series (type4)				
Type	Inverter-based control of hoisting and traversal	2HD-T55-W4	2.8D-T55-W4	2.8HD-T55-W4	3D-T55-W4	3HD-T55-W4	5D-T55-W4	5HD-T55-W4	7.5D-T55-W4	7.5HD-T55-W4	10D-T55-W4	10HD-T55-W4	15D-T88-W4	15HD-T88-W4	20HD-T88-W4	30HD-T88-W4
	Inverter-based control of hoisting only	2HD-T55-V4	2.8D-T55-V4	2.8HD-T55-V4	3D-T55-V4	3HD-T55-V4	5D-T55-V4	5HD-T55-V4	7.5D-T55-V4	7.5HD-T55-V4	10D-T55-V4	10HD-T55-V4	—	—	—	—
Capacity (t)		2	2.8		3		5		7.5		10		15		20	30
Approx. dimensions (mm)	L	12,000	6,000	12,000	6,000	12,000	8,000	12,000	8,000	12,000	8,000	12,000	8,000	12,000	12,000	12,000
	H	310	360		360		560		515		680		785		930	1,090
	K	520	580		580		590		600		600		715		715	850
	R	900	650	950	650	950	900	1,150	1,000	1,150	1,000	1,150	1,000	1,200	1,300	2,000
	E	425	450		450		550		615		650		740		740	935
	F	455	430		430		530		605		615		700		700	905
	W	650	650	650	650	650	850	850	865	865	915	915	1,040	1,040	1,040	1,400
	X	385	399		399		495		548		580		640		640	870
	Y	515	545		545		605		730		735		780		780	875
	A	835	710	870	710	870	845	955	1,075	1,150	1,075	1,150	1,060	1,160	1,210	1,560
	B	675	570	730	570	730	690	800	830	905	885	960	960	990	1,040	1,390
	φ d	56	71		71		90		100		100		130		165	165
	Q	40	51		51		55		67		70		89		91	65
	ℓ	350	325		325		425		433		445		505		505	685
φ M	160	160	160	160	160	160	160	195	195	195	195	250	250	250	350	
φ N	190	190	190	190	190	190	190	225	225	225	225	282	282	282	400	
G	26	26	26	26	26	26	26	29	29	29	29	28	28	28	38	
a	36	42		42		58		69		69		86		108	108	
Rail used		38 square steel or 12-kg rail						44 square steel or 15-kg rail				55 square steel or 22-kg rail				65 square steel or 37-kg rail
Wheel width (mm)		49						53				66				76
Approx. weight (kg)		400	440	510	440	510	695	765	1,100	1,170	1,310	1,400	1,950	2,100	2,250	4,200

Note: 1. Specifications in the table are common to 200V and 400V classes.
 2. As the device contains electronic components, be sure to install a buffering mechanism or buffering material on the stoppers for the longitudinal and traversal.

Low headroom-type hoists

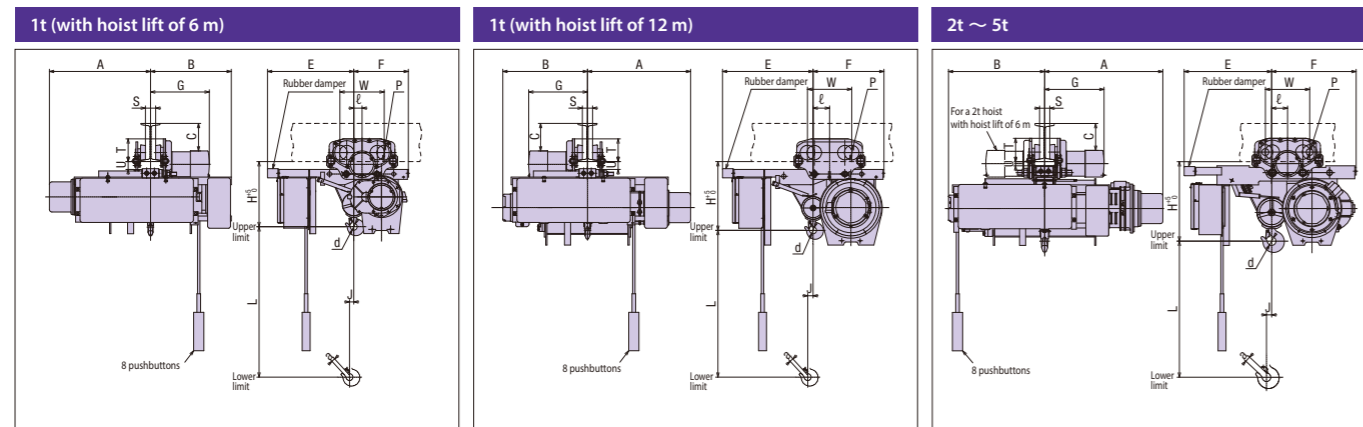

Type	Inverter-based control of hoisting and traversal		1L-T ₃₅ -W ₄		1HL-T ₃₅ -W ₄		2L-T ₃₅ -W ₄		2HL-T ₃₅ -W ₄		2.8L-T ₃₅ -W ₄		2.8HL-T ₃₅ -W ₄		3L-T ₃₅ -W ₄		3HL-T ₃₅ -W ₄		5L-T ₃₅ -W ₄		5HL-T ₃₅ -W ₄								
	Inverter-based control of hoisting only		1L-T ₃₅ -V ₄		1HL-T ₃₅ -V ₄		2L-T ₃₅ -V ₄		2HL-T ₃₅ -V ₄		2.8L-T ₃₅ -V ₄		2.8HL-T ₃₅ -V ₄		3L-T ₃₅ -V ₄		3HL-T ₃₅ -V ₄		5L-T ₃₅ -V ₄		5HL-T ₃₅ -V ₄								
Capacity (t)		1				2				2.8				3				5											
Approx. dimensions (mm)	L	6,000		12,000		6,000		12,000		6,000		12,000		6,000		12,000		6,000		11,000		11,000							
	H	425		450		515		520		600		650		600		650		810		810		810							
	A	665		675		705		775		750		795		750		795		845		955		955							
	B	530		560		605		635		620		700		620		700		690		800		800							
	M	565		595		595		575		635		675		635		675		705		705		705							
	E	360		465		480		560		575		660		575		660		675		675		675							
	W	200/290		200/290		200/290		230/310		230/410		230/310		230/410		230/310		230/410		250/330		250/330							
	K	28		35		42		34		46		50		46		50		35		35		35							
	J	45		56		56		71		71		71		71		71		90		90		90							
	d	96/96		96/96		96/96		128/128		128/128		128/128		128/128		156/140		156/140		156/140		156/140							
	P	23		36		36		42		42		42		42		58		58		58		58							
a	54		108		85		104		100		99		100		99		89		89		89								
Min. curve radius (m)		3.5/1.5				4.5/1.8				5.0/2.0				3.5				5.0/2.0				Straight line/3.5				Straight line/3.0			
Dimensions with respect to I-beam (mm)		G	S	T	U	G	S	T	U	G	S	T	U	G	S	T	U	G	S	T	U	G	S	T	U				
200×100×7		374	42	148	52	378	42	148	32	417	52	177	28	417	52	177	28												
250×125×7.5		387	67	151	49	391	67	151	29	417	52	177	28	417	52	177	28												
300×150×11.5		400	92	160	40	404	92	160	20	430	77	187	18	430	77	187	18	450	77	225	23								
450×175×11										443	102	185	20	443	102	185	20	463	102	223	25								
Approx. weight (kg)		235		315		330		460		455		620		455		620		765		835		835		835		835			

- Notes:
- Specifications in the table are common to 200V and 400V classes.
 - Dimensions W and P indicate [drive side/driven side].
 - The min. curve radius indicates [inverter-based control of traversal/commercial traversal].
 - Unless otherwise specified by the customer, the device delivered will be compatible with I-beams with the dimensions shown in the colored columns.
 - The device contains electronic components. Be sure to install a buffering mechanism or buffering material on the stoppers for longitudinal and traversing movement.
 - The rubber damper is standard on the control panel mounting surface.

Inverter unit for saddles Super V series N1-C₄ and N-5C₄



Load sway reduction function standard

The load sway reduction function can be used when combined with a Hitachi inverter hoist (Super V4).

(For detail of the load sway reduction function, see page 1.)

The load sway reduction function is standard in products produced in and after October 2017. To check whether your device is equipped with the function, refer to the decorative nameplate on the control panel surface.

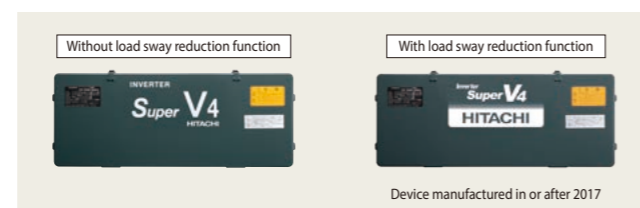

Features

- The unit is ready to use as soon as the installation of the unit and the wiring is completed.
- The unit comes with a circuit breaker and a main power supply MgSW as standard components. There is no need to prepare a shared protection panel.
- A compact inverter unit that is easy to install
- The compact and easy-to-install inverter unit houses all the components in the panel.
- Dramatically reduces impact on and the pendular motion of the suspended load
- The starting and stopping impact reduction function ensures smooth acceleration and deceleration, thereby minimizing impact on and the pendular motion of the suspended load during travel.
- Speed can be changed to achieve efficient operations.
- The travel speed can be set in two stages within 10% of the rated speed.
- Allows selection of optimal line operation speed.
- For some saddles, 150% or 200% speed can be set.

- Easy installation to a crane system
- Equipped with a relay (one unit) that outputs data indicating operating status
- Equipped with two sets of external output circuits in addition the operational inputs
 - Can be used for travel limit input
- Improved ease of maintenance
- Reduced impact also mitigates impact on the mechanical parts of the saddle, thereby extending the service lives of consumable parts.
- Equipped with an 8-digit 7-segment LED display that provides information (such as number of times started) at a glance.
- Operational data can be saved to a USB flash drive.
 - Operational data are output as text data.
 - No USB flash drive is supplied.

Dimensions

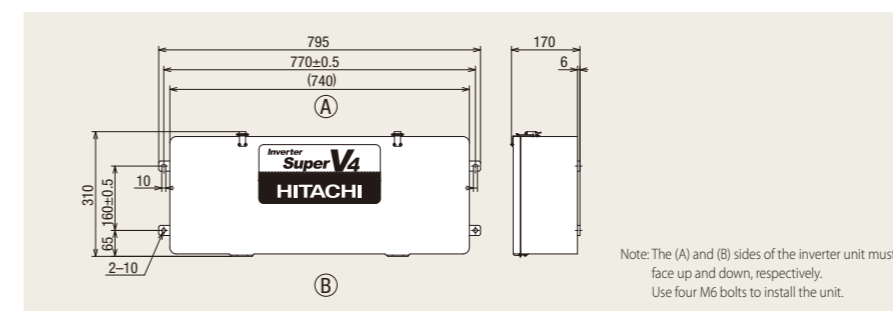

Schematic diagram of electrical wiring

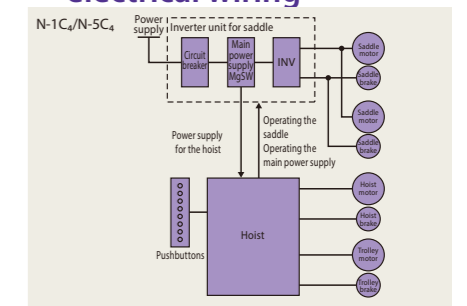

Table of specifications

Select the appropriate model based on hoist and circuit breaker capacity.

Type	N-1C ₄	N-5C ₄
Applicable hoists	1t	2 ~ 5t
Circuit breaker	S-50EB (20A) (built in)	S-50EB (50A) (built in)
Main power supply switch	HS50 (50A) (built in)	
Power supply	200 V class: 3-phase, 200 VAC, 50/60 Hz or 220 VAC, 60Hz 400 V class: 3-phase, 380 VAC, 50/60 Hz; 400 VAC, 50/60 Hz; or 220 VAC, 60Hz	
Power supply system	Power is supplied via cable/trolley cable (use a double-trolley system.)	
Rated speed range	0.0417 m/s to 0.417 m/s (2.5 m/min to 25 m/min) (The factory-set default values are the lowest speed [6 Hz] and highest speed [60 Hz].)	
Repetitive rating	With two 5%ED duty factor and a starting frequency of 250 times per hour For use at 200% of the rated speed: 25%ED duty factor and a starting frequency of 110 times per hour For use at 150% of the rated speed: 25%ED duty factor and a starting frequency of 150 times per hour	
Operation method	Two depressed-position pushbutton inputs (direction signal [examples: south, north] and high-speed signal inputs) supported. 1st depressed position: low speed; 2nd depressed position: high speed	
Protection structure	JIS C0920, IP44 Note: For outdoor use, please install a roof, etc. over the unit.	
Ambient temperature	-10 to +40°C (without freezing)	
Humidity	90% or less (without condensation)	
Paint color	Munsell 2.5B, 2.5/1	
Other	You can attach electromagnetic contactors for alarm and illumination. Operating status detection and abnormal condition detection functions are built into the unit.	
Approx. weight	200 V class: 17 kg 400 V class: 19 kg	
Installation method	Screw the inverter unit on the crane using the mounting holes.	

Applicable range of saddle speed increase

Saddle type	Max. output frequency
THs-10	120Hz
THs-28	120Hz
THs-30	120Hz
THLs-30	120Hz
THs-56	90Hz
THLs-56	90Hz
TLMs-10	90Hz
TLMs-28	90Hz
TLMs-30	90Hz
TLMs-45	90Hz