

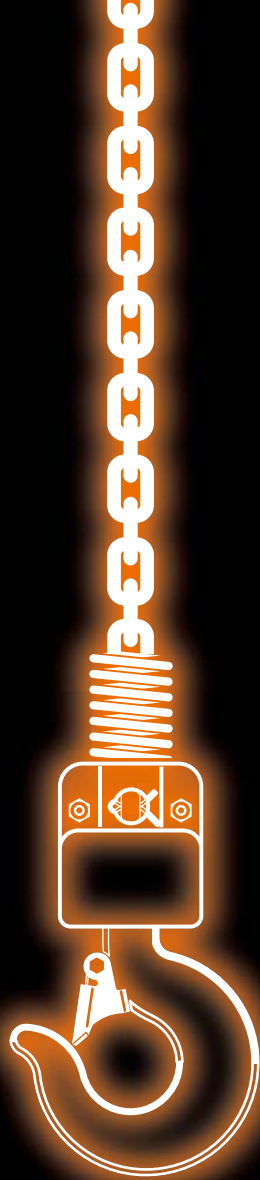

Chain Hoists

HITACHI
Inspire the Next



Hitachi Chain Hoist Catalog

Hitachi Electric Chain Hoist

L series

S series

F series

Hitachi Electric Chain Hoist

Widely used to improve the efficiency of material handling (and transportation).

Hitachi chain hoist can be used for a wide range of purposes from primary to tertiary industries such as general machine, vehicle and can manufacturing factories as well as warehouses and retail stores.



Contents

● Introduction ————— 1-2

Outline

● List of Model Series ————— 3

● Standard Specifications ————— 4

● Model Explanation ————— 4

● Series Selection ————— 4

● Operating Conditions and Model Selection Method — 5

● Standard Specifications Quick Reference — 6

● Features

Standard Model ————— 7-8

CE Marking Model ————— 9-10

L series

● Suspension type ————— 11

● 2-point Pushbutton Switch type ————— 12

● 3-point Pushbutton Switch type ————— 12

S series

■ Suspension type ————— 13-14

● With motorized trolley - ET ————— 15

● With motorized trolley - ST ————— 16

● With chain driven trolley - BC ————— 17

● With manual driven trolley - BP ————— 18

F series

● Suspension type ————— 19-20

● With motorized trolley - ET ————— 21

● With motorized trolley - ST ————— 22

● With chain driven trolley - BC ————— 23

● With manual driven trolley - BP ————— 24

Others

● Crane wiring unit ————— 25

● Dedicated electric chain hoist ————— 26-28

● Technical materials ————— 29

Outline

L series

S series

F series

Others

You can make an exacting model selection based on such operating conditions as capacity and speed.

L series Higher durability, speed and safety with compact body developed for light load daily use.

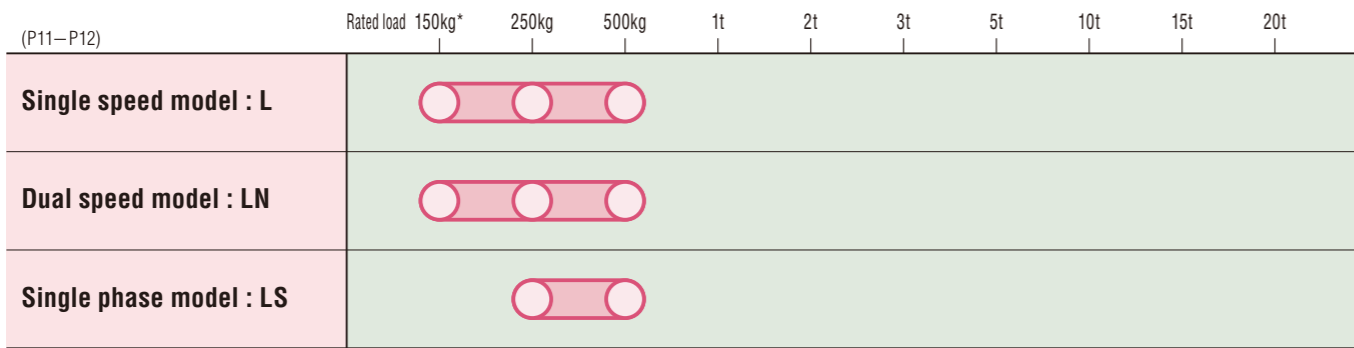

*Without overload limiter device

S series Suitable for general work. Economical standard speed model.

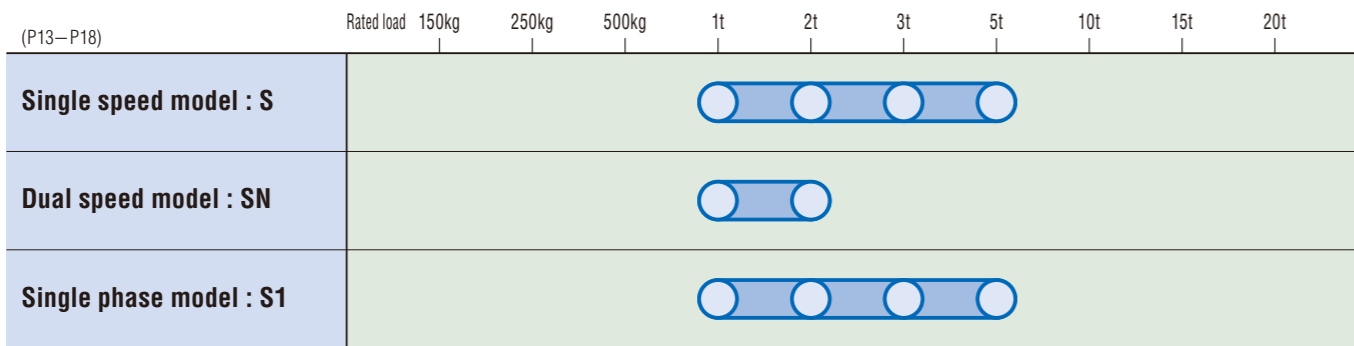

F series High-speed model that is sturdy and suitable for high-speed work.

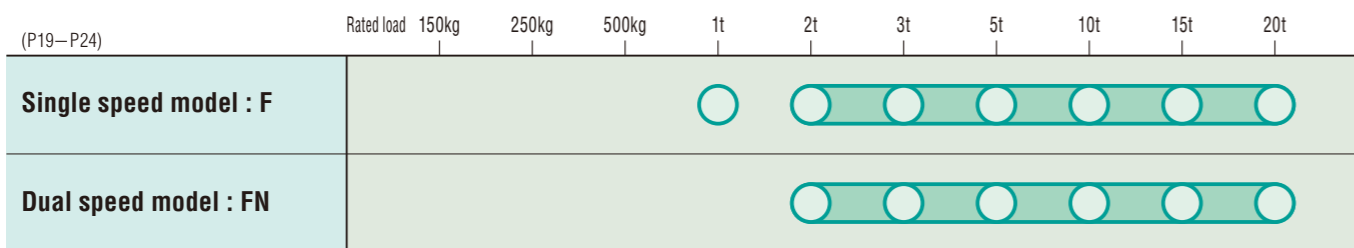

Trolley series

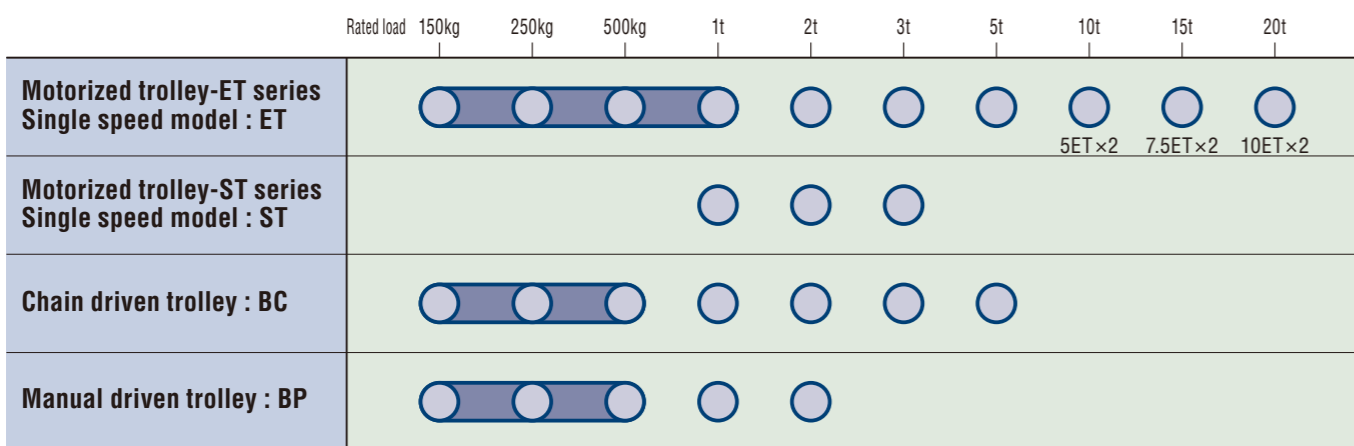

Dedicated electric chain hoist contents

- Twin hook type electric chain hoist — 26
- Optional power source electric chain hoist and trolley — 27
- Optional control voltage model — 27
- Electric chain hoist with the Hi-plated chain — 27
- Electric chain hoist with overload prevention unit (with OL) — 27
- With geared limit switch (UDS) — 27
- Other products with changed specifications
Lift change (extension), etc. — 28-29

Standard Specifications

Specifications		Standard model	CE Making model
Power Source*	50Hz	3 phase : 220/380-415V 3 phase : 346-380V 1 phase : 200-220V	1 phase : 220-240V
	60Hz	3 phase : 220V, 220-230/440-460V 1 phase : 110V, 220V	—
Operation Method		Operating pushbutton	
Control Voltage		24V	
Power Method		Suspension type with manual driven trolley or chain driven trolley : with 5m cable With motorized trolley : cable and catch are not included with standard shipment	
Pushbutton Switch	2(3)	single speed	STOP
		dual speed	STOP
	4(5)	single speed	STOP
		dual speed	STOP
6(7)	single speed	STOP	
	dual speed	STOP	
Color(Munsell)		Orange(2.5YR 6/12)	
Electrical Protection		IP54(Trolley : IP44) (Equivalent when stuffing drain hole)	
Insulation Class of Motor		E	
Rating**		30%ED, 180starts/h(F series)***	
Classification		ISO M4, FEM 1Am	
Standards		Machinery : 2006/42/EC EMC : 2004/108/EC	

* For power sources other than those listed, see the dedicated electric chain hoists (page25).
 ** This shows the value at a load of 63% of the rated load.
 ** Make sure the average value per hour is not exceeded even during concentrated use in a short time.
 ** Dual speed models have an added low speed to allow fine movement operation and improve workability by reducing inching. The rating shows the value when the high speed and the low speed, the operation time of which is 1/10 of the high speed, are combined.
 *** Please refer to each specification table for the model except the F series.

Series Selection

When selecting an electric chain hoist, the operating environment, operating time, and operating frequency must be taken into consideration.

Operating time and load ratio

Use within the range of section.

Hitachi chain hoists belong to M4 classification

Load Condition	Load Ratio	Mean operating hour per day (h)*						Total operating time(h)**						
		0.25	0.5	1	2	4	8	200	400	800	1,600	3,200	6,300	
Light	$K \leq 0.5$							—	—	M1	M2	M3	M4	
Medium	$0.5 < K \leq 0.63$							—	M1	M2	M3	M4	M5	
Heavy	$0.63 < K \leq 0.8$				L, S, F series			M1	M2	M3	M4	M5	M6	
Severe	$0.8 < K$							M2	M3	M4	M5	M6	—	

Load condition

Light : This is normally used at a load of 1/2 the rated load, and on rare occasions at the rated load.

Medium : This is normally used at a load of 1/2 to 2/3 the rated load, and occasionally at the rated load.

Heavy : This is normally used at loads above 2/3 the rated load, and often at the rated load.

Severe : This is mostly used at the rated load or close to this load.

* If use is expected to exceed the above range, then an electric chain hoist with a higher capacity must be selected, so please consult with HITACHI.

** Above range is made for machine parts such as gears and bearings.

Operating environment

- Use in locations with an ambient temperature of -10°C to 40°C (with no freezing) and humidity of 90% or less (no condensation).

In addition to the general specifications, (1) starting frequency, (2) duty factor, and (3) load ratio must be taken into consideration.

Calculation method

(If the calculated value exceeds the standard specification, then it is a dedicated specification.)

(1) Max. starting frequency α (Starts/h) = $2 \times n \times N$

● Example calculation

The starting frequency is the cumulative sum of the inching operation count, so this must be calculated by estimating the number of inchings per hoist round trip.

$$2 \times 3 \times 25 = 150 \text{ Starts/h}$$

Lifting+Lowering (Number of times) — No. of transfer per hour (times) — Inching count (times) per lifting or lowering operation.

(2) The total motor ON time (minutes) per hour under the most frequent condition.

$$\text{Duty factor } \beta (\%) = \frac{\text{Lift(m)} \times \text{No. of transfer per hour (Times)}}{60 \text{ min}} \times 100 = 2 \times \frac{\ell}{V} \times N \times \frac{1}{60 \text{ min}} \times 100$$

● Example calculation

$$2 \times \frac{3}{10} \times 25 \div 60 \times 100 = 25\%$$

Lifting+Lowering (Times) — 1 hour (60 min) — Hoisting speed (m/min)

(3) Load ratio $K = \sqrt[3]{P_1 \cdot t_1 + P_2 \cdot t_2 + P_3 \cdot t_3 + \dots}$

● Example calculation

When a 0.4t load is suspended on a 1-ton rated load electric chain hoist for a one-way trip, with a no-load return trip. (The lifting sling is 0.3t).

$$K = \sqrt[3]{(0.3+0.4)^3 \times 0.5 + 0.3^3 \times 0.5} = 0.57$$

In this case, the load condition is comparable to "medium" and the average operating time per day is 2 hours or less. If used for a longer time than this, an electric chain hoist with a higher capacity must be selected.

n : Inching count (times) per lifting or lowering operation.
 N : Transport count (times) within 1 hour
 ℓ : Lift(m)
 V : Hoisting speed(m/min)
 $t_1, t_2, t_3 \dots$: Ratio of the operating time of each load to the total operating time
 $P_1, P_2, P_3 \dots$: Each load ratio (ratio of the load to each rated load)

Model Explanation

● For suspension types

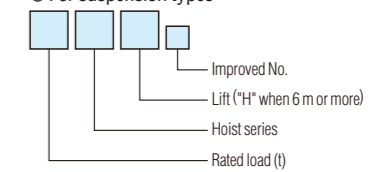

Ex. 2t, S series, Lift 6m

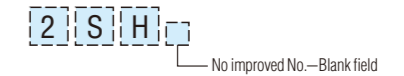

● For with trolley

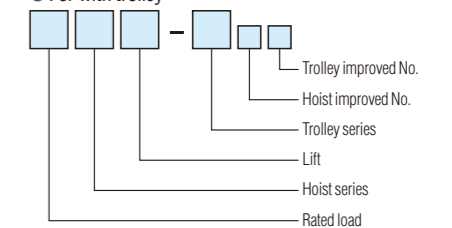

Ex. 1t, SN series, Lift 3m, With motorized trolley-ET



* Separate product name plates are placed on the hoist unit and the trolley unit

Ex. 1SN-ET: Hoist unit name plate "1SN" / Trolley unit name plate "1ET"

Operating Conditions and Model Selection Method

Select a model from the following that is suitable for the operating conditions.

Operating Conditions	Main Unit	Trolley	Pushbutton Cable	Crane Saddle	Option
Suspension Type	L series S series F series	—	Power cable Pushbutton cable		
Manual Driven Trolley Type	<p>P11 P17</p>	BP series P16 P22	2PB(H) For single speed 2PBN(H) For double speed		
Chain Driven Trolley Type		BC series P15 P21	4PB(H) 4PBN(H)		
Motorized Trolley Type		ST series P13 P20	6PB(H) 6PBN(H)	Crane saddle TLM series TH series SL series SLM series	Crane girder switch unit (24V operation) GMB-10
Motorized Trolley Motorized Travel Type		ET series P13 P20	6PB(H) 6PBN(H)		
Manual Driven Trolley Motorized Travel Type		BP series P16 P22	4PB(H)-C 4PBN(H)-C		
Chain Driven Trolley Motorized Travel Type		BC series P15 P21	4PB(H)-C 4PBN(H)-C		

* The operation method is a pushbutton operation. Indirect 24V control voltage.
* A power cable is not included with the trolley. Refer to the Power cable in the list below and prepare a suitable one.

Pushbutton cable

Standard Model

	Type	Lift (m)	Number of Pushbutton Switch	Material of Cable		Pushbutton Switch		
				For Pushbutton Cable	For Power Cable	Character	① ②	③ ④
For Single Speed Type	2PB	3	2	T-VCT 3CX0.75mm ²	VCT 4CX2mm ²	Character	① ②	
	2PBH	6				Contact	2a	
	4PB	3	4	T-VCT 5CX0.75mm ²	—	Character	① ②	③ ④
	4PBH	6				Contact	2a	2a
	6PB	3	6	T-VCT 8CX0.75mm ²	—	Character	① ②	③ ④
	6PBH	6				Contact	2a	2a
For Dual Speed Type	2PBN	3	2	T-VCT 5CX0.75mm ²	VCT 4CX2mm ²	Character	① ②	
	2PBNH	6				Contact	4a+2b	
	4PBN	3	4	T-VCT 6CX0.75mm ²	—	Character	① ②	③ ④
	4PBNH	6				Contact	4a+2b	2a
	6PBN	3	6	T-VCT 8CX0.75mm ²	—	Character	① ②	③ ④
	6PBNH	6				Contact	4a+2b	2a

CE Version

	Type	Lift (m)	Number of Pushbutton Switch	Material of Cable		Pushbutton Switch			
				For Pushbutton Cable	For Power Cable	Character	① ②	③ ④	⑤ ⑥
For Single Speed Type	3PBE	3	3	T-VCT 4CX0.75mm ²	VCT 4CX2mm ²	Character	(STOP)	① ②	
	3PBEH	6				Contact	1b	2a	
	5PBE	3	5	T-VCT 7CX0.75mm ²	—	Character	(STOP)	① ②	③ ④
	5PBEH	6				Contact	1b	2a	2a
	7PBE	3	7	T-VCT 8CX0.75mm ²	—	Character	(STOP)	① ②	③ ④
	7PBEH	6				Contact	1b	2a	2a
For Dual Speed Type	3PBE	3	3	T-VCT 5CX0.75mm ²	VCT 4CX2mm ²	Character	(STOP)	① ②	
	3PBEH	6				Contact	1b	4a+2b	
	5PBE	3	5	T-VCT 7CX0.75mm ²	—	Character	(STOP)	① ②	③ ④
	5PBEH	6				Contact	1b	4a+2b	2a
	7PBE	3	7	T-VCT 9CX0.75mm ²	—	Character	(STOP)	① ②	③ ④
	7PBEH	6				Contact	1b	4a+2b	2a

Standard Specifications Quick Reference

Hoist main unit

Capacity (kg)	Hoisting Speed (m/min)(50/60Hz)	Motor (kW)(50/60Hz)	Power Source (phase)	Chain		Lift (m)	Type	See page	Function					
				Main	Creep				Dia. (mm)	No. of falls	Automatic Adjusting Brake	Reverse Phase Inspecting Relay	Auxiliary Brake System	
150	Single	14.4/17	—	0.38/0.45	—	3	6.3	1	3	1/6L	12	—	—	—
150	Single	14.4/17	—	0.38/0.45	—	3	6.3	1	6	1/6LH	12	—	—	—
150	Dual	14.4/17	3.6/4.3	0.38/0.45	0.10/0.11	3	6.3	1	3	1/6LN	12	—	—	—
150	Dual	14.4/17	3.6/4.3	0.38/0.45	0.10/0.11	3	6.3	1	6	1/6LNH	12	—	—	—
250	Single	10/12	—	0.45/0.55	—	3	6.3	1	3	1/4L	12	—	—	—
250	Single	10/12	—	0.45/0.55	—	3	6.3	1	6	1/4LH	12	—	—	—
250	Dual	10/12	2.5/3.0	0.45/0.55	0.11/0.14	3	6.3	1	3	1/4LN	12	—	—	—
250	Dual	10/12	2.5/3.0	0.45/0.55	0.11/0.14	3	6.3	1	6	1/4LNH	12	—	—	—
250	Single	5.0/6.0	—	0.25/0.30	—	1	6.3	1	3	1/4LS	12	—	—	—
250	Single	5.0/6.0	—	0.25/0.30	—	1	6.3	1	6	1/4LSH	12	—	—	—
500	Single	7.2/8.5	—	0.63/0.75	—	3	6.3	1	3	1/2L	12	—	—	—
500	Single	7.2/8.5	—	0.63/0.75	—	3	6.3	1	6	1/2LH	12	—	—	—
500	Dual	7.2/8.5	1.8/2.1	0.63/0.75	0.16/0.19	3	6.3	1	3	1/2LN	12	—	—	—
500	Dual	7.2/8.5	1.8/2.1	0.63/0.75	0.16/0.19	3	6.3	1	6	1/2LNH	12	—	—	—
500	Single	3.6/4.3	—	0.30/0.35	—	1	6.3	1	3	1/2LS	12	—	—	—
500	Single	3.6/4.3	—	0.30/0.35	—	1	6.3	1	6	1/2LSH	12	—	—	—
1,000	Single	4.6/5.5	—	0.8/1.0	—	3	7.1	1	3	1S	13.14	—	—	—
1,000	Single	4.6/5.5	—	0.8/1.0	—	3	7.1	1	6	1SH	13.14	—	—	—
1,000	Single	7.1/8.5	—	1.3/1.6	—	3	7.1	1	3	1F	19.20	○	○	○
1,000	Single	7.1/8.5	—	1.3/1.6	—	3	7.1	1	6	1FH	19.20	○	○	○
1,000	Dual	4.6/5.5	1.2/1.4	0.8/1.0	0.2/0.25	3	7.1	1	3	1SN	13.14	—	○	—
1,000	Dual	4.6/5.5	1.2/1.4	0.8/1.0	0.2/0.25	3	7.1	1	6	1SNH	13.14	—	○	—
1,000	Single	2.3/2.8	—	0.4/0.5	—	1	7.1	1	3	1S1	13.14	—	—	—
1,000	Single	2.3/2.8	—	0.4/0.5	—	1	7.1	1	6	1SH1	13.14	—	—	—
2,000	Single	2.3/2.8	—	0.8/1.0	—	3	7.1	2	3	2S	13.14	—	○	—
2,000	Single	2.3/2.8	—	0.8/1.0	—	3	7.1	2	6	2SH	13.14	—	○	—
2,000	Single	6.8/8.2	—	2.4/2.9	—	3	10	1	3	2F	19.20	○	○	○
2,000	Single	6.8/8.2	—	2.4/2.9	—	3	10	1	6	2FH	19.20	○	○	○
2,000	Dual	2.3/2.8	0.6/0.7	0.8/1.0	0.2/0.25	3	7.1	2	3	2SN	13.14	—	○	—
2,000	Dual	2.3/2.8	0.6/0.7	0.8/1.0	0.2/0.25	3	7.1	2	6	2SNH	13.14	—	○	—
2,000	Dual	6.8/8.2	1.7/2.1	2.4/2.9	0.6/0.7	3	10	1	3	2FN	19.20	○	○	○
2,000	Dual	6.8/8.2	1.7/2.1	2.4/2.9	0.6/0.7	3	10	1	6	2FNH	19.20	○	○	○
2,000	Single	1.1/1.4	—	0.4/0.5	—	1	7.1	2	3	2S1	13.14	—	—	—
2,000	Single	1.1/1.4	—	0.4/0.5	—	1	7.1	2	6	2SH1	13.14	—	—	—
3,000	Single	1.5/1.8	—	0.8/1.0	—	3	7.1	3	3	3S	13.14	—	—	—
3,000	Single	1.5/1.8	—	0.8/1.0	—	3	7.1	3	6	3SH	13.14	—	—	—
3,000	Single	4.1/4.9	—	2.4/2.9	—	3	10	2	3	3F	19.20	○	○	○
3,000	Single	4.1/4.9	—	2.4/2.9	—	3	10	2	6	3FH	19.20	○	○	○
3,000	Dual	4.0/4.8	1.0/1.2	2.4/2.9	0.6/0.7	3	10	2	3	3FN	19.20	○	○	○
3,000	Dual	4.0/4.8	1.0/1.2	2.4/2.9	0.6/0.7	3	10	2	6	3FNH	19.20	○	○	○
5,000	Single	0.9/1.1	—	0.8/1.0	—	3	7.1	5	3	5S	13.14	—	—	—
5,000	Single	0.9/1.1	—	0.8/1.0	—	3	7.1	5	6	5SH	13.14	—	—	—
5,000	Single	2.8/3.3	—	2.4/2.9	—	3	10	3	3	5F	19.20	○	○	○
5,000	Single	2.8/3.3	—	2.4/2.9	—	3	10	3	6	5FH	19.20	○	○	○
5,000	Dual	2.8/3.3	0.7/0.8	2.4/2.9	0.6/0.7	3	10	3	3	5FN	19.20	○	○	○
5,000	Dual	2.8/3.3	0.7/0.8	2.4/2.9	0.6/0.7	3	10	3	6	5FNH	19.20	○	○	○
10,000	Single	2.8/3.3	—	2.4/2.9x2	—	3	10	4	6	10FH	19.20	○	○	○
10,000	Dual	2.8/3.3	0.7/0.8	2.4/2.9x2	0.6/0.7x2	3	10	4	6	10FNH	19.20	○	○	○
15,000	Single	1.8/2.2	—	2.4/2.9x2	—	3	10	6	6	15FH	19.20	○	○	○
15,000	Dual	1.8/2.2	0.45/0.55	2.4/2.9x2	0.6/0.7x2	3	10	6	6	15FNH	19.20	○	○	○
20,000	Single	1.4/1.6	—	2.4/2.9x2	—	3	10	8	6	20FH	19.20	○	○	○

Motorized trolley

Rated Load	Model Name	Traveling Speed (m/min)		Applicable Beam Width (mm)	Min. Curve Radius (m)	Page
		50Hz	60Hz			
250kg-1t	1ET 1ST	21·10.5	25·12.5	75-125	1.5	13, 14 19, 20
2t	2ET 2ST				1.8	
3t	3ET 3ST	100-150			2.5	
5t	5ET				3.0	
10t	5ETx2	10.5	12.5	150, 175	5.0	
15t	7.5ETx2				5.0	
20t	10ETx2	14	17	175, 190	Straight	

Chain driven trolley

Rated Load	Model Name	Applicable Beam Width (mm)	Min. Curve Radius (m)
250-500kg	1/2BC(H)	75-125	1.0
1t	1BC(H)		1.2
2t	2BC(H)	100-150	1.5
3t	3BC(H)		1.5
5t	5BCH	125-175	2.4

Crane saddle

Model Configuration	Max. Wheel Load (t)	Max. Span (m)	Traveling Speed (m/min)	Model Name	Main Unit Frame Structure																																							
						<table border="0"> <tr> <td rowspan="6">Toprun Type Crane Saddle</td> <td>1</td><td>10</td><td rowspan="6">21/25</td> <td>TL5-10</td><td rowspan="2">Inverted hat cross-section structure</td> </tr> <tr> <td>2.8</td><td>12</td> <td>TH5-10</td> </tr> <tr> <td>1</td><td>10</td> <td>TH5-28</td><td rowspan="4">Double channel structure (TH5-10, TH5-28 Use uniform thickness channel steel)</td> </tr> <tr> <td>2.8</td><td>12</td> <td>TH5-30</td> </tr> <tr> <td>3</td><td>16</td> <td>TH5-56</td> </tr> <tr> <td>5.6</td><td>18</td> <td>TH-112</td> </tr> <tr> <td rowspan="2">Suspension Crane Saddle</td> <td>11.2</td><td>20</td> <td>25/30</td> <td>TH-112</td> <td rowspan="2">L-shaped frame structure</td> </tr> <tr> <td>0.6</td><td>10</td> <td rowspan="2">21/25</td> <td>SL-6</td> </tr> <tr> <td>1</td><td>10</td> <td>SL5-10</td><td rowspan="2">Double channel structure (SL5-10, SL5-28 Use uniform thickness channel steel)</td> </tr> <tr> <td>2.8</td><td>12</td> <td>SL5-28</td> </tr> </table>						Toprun Type Crane Saddle	1	10	21/25	TL5-10	Inverted hat cross-section structure	2.8	12	TH5-10	1	10	TH5-28	Double channel structure (TH5-10, TH5-28 Use uniform thickness channel steel)	2.8	12	TH5-30	3	16	TH5-56	5.6	18	TH-112	Suspension Crane Saddle	11.2	20	25/30	TH-112	L-shaped frame structure	0.6	10	21/25	SL-6	1
Toprun Type Crane Saddle	1	10	21/25	TL5-10	Inverted hat cross-section structure																																							
	2.8	12		TH5-10																																								
	1	10		TH5-28	Double channel structure (TH5-10, TH5-28 Use uniform thickness channel steel)																																							
	2.8	12		TH5-30																																								
	3	16		TH5-56																																								
	5.6	18		TH-112																																								
Suspension Crane Saddle	11.2	20	25/30	TH-112	L-shaped frame structure																																							
	0.6	10	21/25	SL-6																																								
1	10	SL5-10		Double channel structure (SL5-10, SL5-28 Use uniform thickness channel steel)																																								
2.8	12	SL5-28																																										

Manual driven trolley

Rated Load	Model Name	Applicable Beam Width (mm)	Min. Curve Radius (m)
250-500kg	1/2BP	75-125	1.0
1t	1BP		1.2
2t	2BP	100-150	1.5

Outline

L series

S series

F series

Others

Hitachi Electric Chain Hoists are Packed with Advanced Features

STANDARD MODEL L series **L** / S series **S** / F series **F**

HELICAL GEARING **L S F**

used where practical to provide quiet operation.

LONG LIFE BRAKE UNIT **L S F**

Disk type Electro-Magnetic brake system for steady operation and long life.

AUTOMATIC ADJUSTING BRAKE **F**

are equipped with patented Automatic Adjusting Brake for easier maintenance and added safety. U.S. PAT. 3908802 Germany PAT. 2354044



ELECTRO-MAGNETIC CONTACTOR **L S F**

with mechanical-interlocking against line short by mechanical shock.

POWER CHAIN **L S F**

special (patented) alloy steel chain surface hardened for optimum strength and wear resistance. (U.S. PAT. 3830054)

CHAIN CONTAINER **L S F**

as standard part for safer operation.

LOWER HOOK **L S F**

is heat-treated and equipped with safety latch and 360° swivelling.

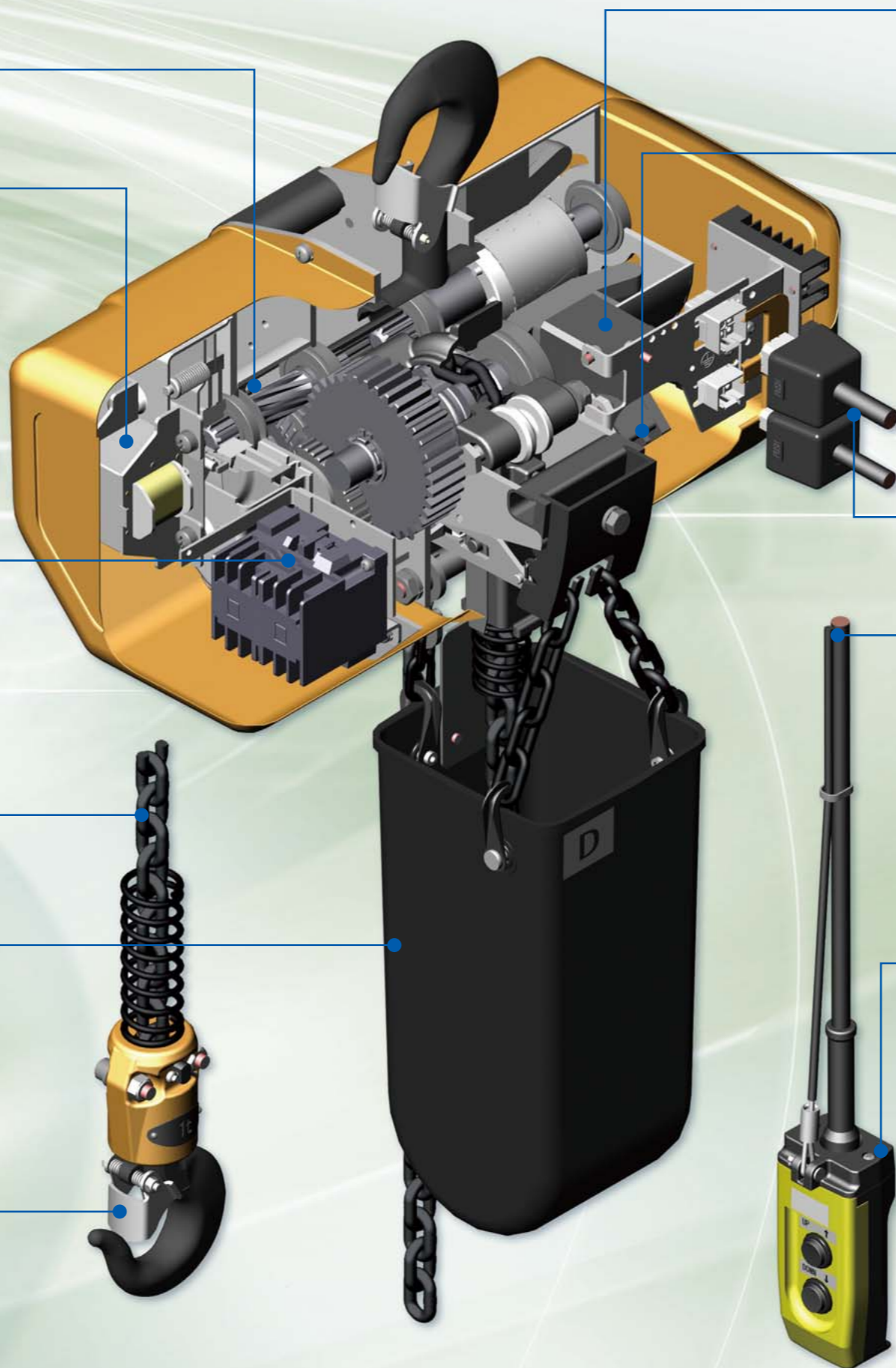

REVERSE PHASE INSPECTION RELAY **S F**

cut control circuit when reverse phasing. Except the 3 phase models of 250 kg and 500 kg, and single phase models.

LIMIT SWITCH (Upper and Lower) **L S F**

interrupt motor power to prevent hook overtravel and hazardous condition such as chain kink.

AUXILIARY BRAKE SYSTEM **F**

F series hoists equipped with auxiliary brake.



PLUG-IN CABLES **L S F**

reduce maintenance time and installation.

PUSHBUTTON CABLE **L S F**

is molded with strain relief wire rope into one body. This assures easier and safer operation.

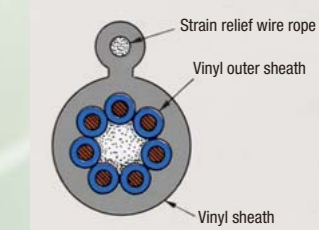

PUSHBUTTON SWITCH **L S F**

is rain-proof plastic for severe impact and corrosive atmosphere resistance and mechanically interlocked. The 24 volt control circuit reduce shock hazard to the operation.

HITACHI OVERLOAD LIMITER **L option S option F option**

Unique, patented over load protection device is available on all models upon request. U.S. PAT. 4103873 CANADA PAT. 1062232 Others

Not available for 1/6L, 1/6LH, 1/6LN, 1/6LNH

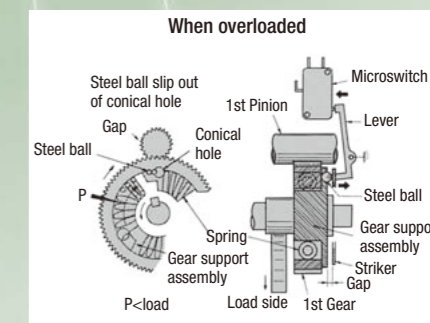

Outline

L series

S series

F series

Others

Conform with Essential Requirements Set Out in European Directives



CE MARKING MODEL L series **L** / S series **S** / F series **F**

LONG LIFE BRAKE UNIT **L S F**

Disk type Electro-Magnetic brake system for steady operation and long life.

AUTOMATIC ADJUSTING BRAKE **F**

are equipped with patented Automatic Adjusting Brake for easier maintenance and added safety. U.S. PAT. 3908802 Germany PAT. 2354044



ELECTRO-MAGNETIC CONTACTOR **L S F**

with mechanical-interlocking against line short by mechanical shock.

POWER CHAIN **L S F**

special (patented) alloy steel chain surface hardened for optimum strength and wear resistance. (DIN-5684-8)

CHAIN CONTAINER **L S F**

as standard part for safer operation.

LOWER HOOK **L S F**

is heat-treated and equipped with safety latch and 360° swivelling.

TRANSFORMER

Fuse is built in a primary side to prevent overheat.

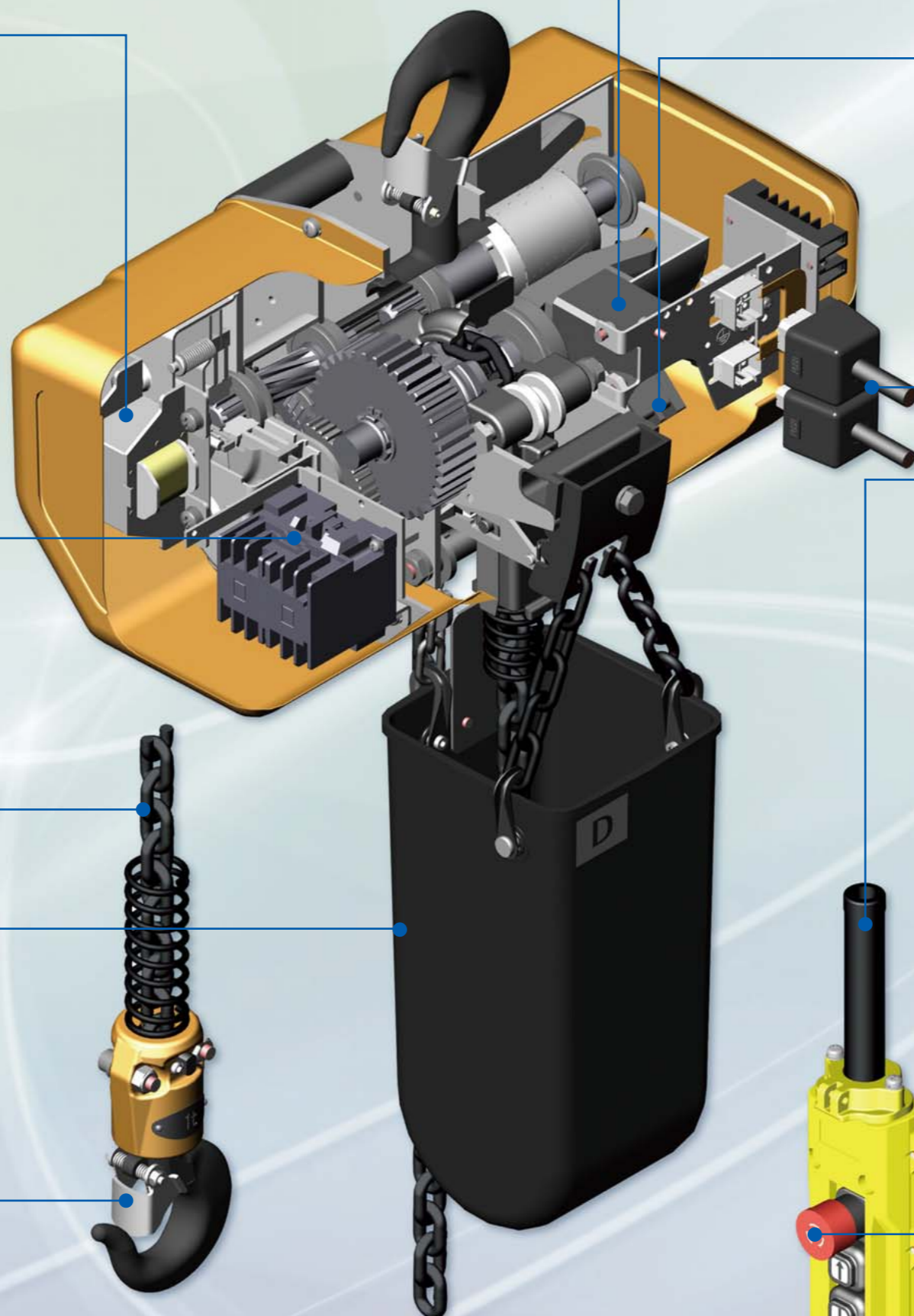
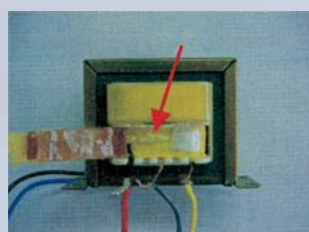

REVERSE PHASE INSPECTING RELAY **S F**

cut control circuit when reverse phasing. Except the 3 phase models of 250 kg and 500 kg, and single phase models.

LIMIT SWITCH (Upper and Lower) **L S F**

interrupt motor power to prevent hook overtravel and hazardous condition such as chain kink.

AUXILIARY BRAKE SYSTEM **F**

F series hoists equipped with auxiliary brake.



PLUG-IN CABLES **L S F**

reduce maintenance time and installation.

PUSHBUTTON CABLE **L S F**

is molded with strain relief wire rope into one body. This assures easier and safer operation.

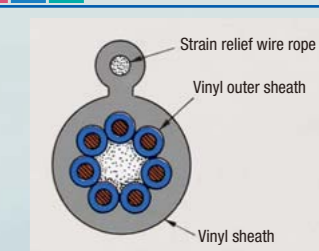

PUSHBUTTON SWITCH **L S F**

is rain-proof plastic for severe impact and corrosive atmosphere resistance and mechanically interlocked. The 24 volt control circuit reduce shock hazard to the operation.

- **EMERGENCY STOP BUTTON**
The chain hoist can be stopped in emergency cases that are caused by overdrive or erroneous operation.



HITACHI OVERLOAD LIMITER **L S F**

Unique, patented over load protection device is available on all models upon request. U.S. PAT. 4103873 CANADA PAT. 1062232 Others

Not available for 1/6L, 1/6LH, 1/6LN, 1/6LNH

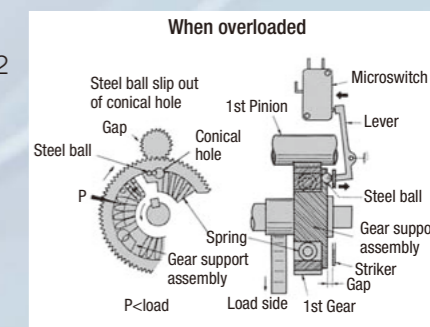

Outline

L series

S series

F series

Others

L series

Electric chain hoist

Suspension type

Single speed model

Dual speed model

Single phase model



HIGHER DURABILITY

- The load rating is 40% ED* which is a significant improvement over other previous models.
*L model

EASY SLINGING WORK

- The new hook allows for easy slinging work with the wide hook dimension.

Specifications table

SINGLE SPEED (3 PHASE)

L(H)		1/6L (H)*	1/4L (H)	1/2L (H)
Model Name				
Rated Load (kg)		150	250	500
Rating (%ED)		40		
Max.Starting Frequency (Starts/h)		240		
Hoisting Speed (m/min)	50Hz	14.4	10	7.2
	60Hz	17	12	8.5
Hook Dimensions (mm)		27		

*without overload limiter device

SINGLE PHASE

LS(H)		1/4LS (H)	1/2LS (H)
Model Name			
Rated Load (kg)		250	500
Rating (%ED)		25	
Max.Starting Frequency (Starts/h)		150	
Hoisting Speed (m/min)	50Hz	5.0	3.6
	60Hz	6.0	4.3
Hook Dimensions (mm)		27	

DUAL SPEED (3 PHASE)

LN(H)		1/6LN (H)*	1/4LN (H)	1/2LN (H)
Model Name				
Rated Load (kg)		150	250	500
Rating (%ED)		30		
Max.Starting Frequency (Starts/h)		180		
Hoisting Speed (m/min)	50Hz	14.4/3.6	10/2.5	7.2/1.8
	60Hz	17/4.3	12/3.0	8.5/2.1
Hook Dimensions (mm)		27		

*without overload limiter device

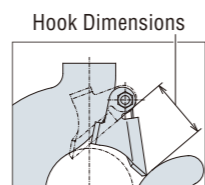

HIGHER SAFETY

- The new chain container next to the main body of the hoist prevents unnecessary movement of the chain container and Lower hook doesn't touch the chain container.
- The new Hook Latch has a claw. The claw grips on to the hook securely.

2-point Pushbutton Switch type

Dimensions

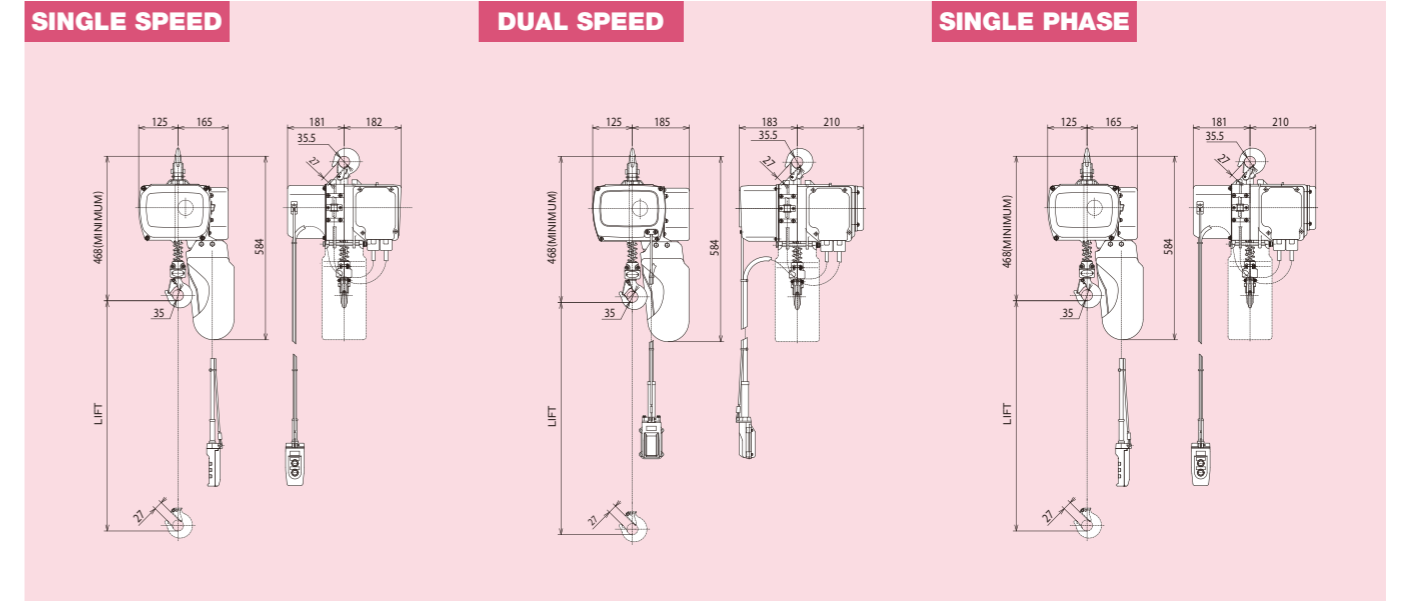

Specifications table

Model Name		1/6L,1/4L,1/2L	1/6LH,1/4LH,1/2LH	1/6LN,1/4LN,1/2LN	1/6LNH,1/4LNH,1/2LNH	1/4LS,1/2LS	1/4LSH,1/2LSH
Lift (m)	Lift	3	6	3	6	3	6
	Falls		1		1		1
Link Chain	Dia.	6.3		6.3		6.3	
	Pitch	19.1		19.1		19.1	
	Approx. Weight (kg)	32	35	35	38	34	37

3-point Pushbutton Switch type

Dimensions

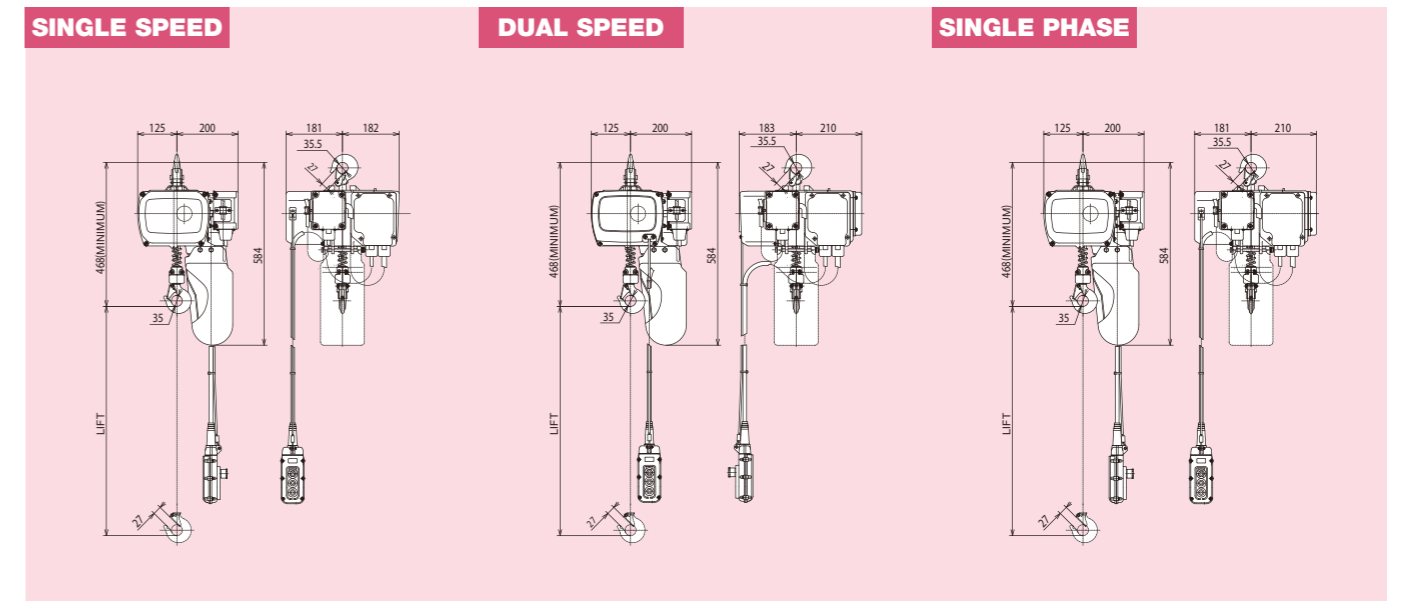

Specifications table

Model Name		1/6L,1/4L,1/2L	1/6LH,1/4LH,1/2LH	1/6LN,1/4LN,1/2LN	1/6LNH,1/4LNH,1/2LNH	1/4LS,1/2LS	1/4LSH,1/2LSH
Lift (m)	Lift	3	6	3	6	3	6
	Falls		1		1		1
Link Chain	Dia.	6.3		6.3		6.3	
	Pitch	19.1		19.1		19.1	
	Approx. Weight (kg)	33	36	36	39	35	38

S series

Electric chain hoist

Suspension type

Single speed model

Dual speed model

Single phase model



Specifications table

SINGLE SPEED (3 PHASE)

S(H)		1S(H)	2S(H)	3S(H)	5S(H)
Model Name		1,000	2,000	3,000	5,000
Rated Load (kg)		1,000	2,000	3,000	5,000
Standard Lift (m)		3(6)			
Hoisting Speed (m/min)	50Hz	4.6	2.3	1.5	0.9
	60Hz	5.5	2.8	1.8	1.1
Motor Output (kW)	50Hz	0.8	0.8	0.8	0.8
	60Hz	1.0	1.0	1.0	1.0
Link Chain	Dia. (mm)	φ7.1	φ7.1	φ7.1	φ7.1
	No. of Falls	1	2	3	5
Rating		25% ED			
Power Cord Length		5m			

DUAL SPEED (3 PHASE)

SN(H)		1SN(H)	2SN(H)
Model Name		1,000	2,000
Rated Load (kg)		1,000	2,000
Standard Lift (m)		3(6)	
Hoisting Speed (m/min)	50Hz	4.6/1.2	2.3/0.6
	60Hz	5.5/1.4	2.8/0.7
Motor Output (kW)	50Hz	0.8/0.2	0.8/0.2
	60Hz	1.0/0.25	1.0/0.25
Link Chain	Dia. (mm)	φ7.1	φ7.1
	No. of Falls	1	2
Rating		20/10% ED	
Power Cord Length		5m	

SINGLE PHASE

SS(H) ₂ , S(H) ₁		1S(H) ₁	2S(H) ₁
Model Name		1,000	2,000
Rated Load (kg)		1,000	2,000
Standard Lift (m)		3(6)	
Hoisting Speed (m/min)	50Hz	2.3	1.1
	60Hz	2.8	1.4
Motor Output (kW)	50Hz	0.4	0.4
	60Hz	0.5	0.5
Link Chain	Dia. (mm)	φ7.1	φ7.1
	No. of Falls	1	2
Rating		20% ED	
Power Cord Length		5m	

All dimensions and specifications are subject to change without notice.

Suspension type

Dimensions

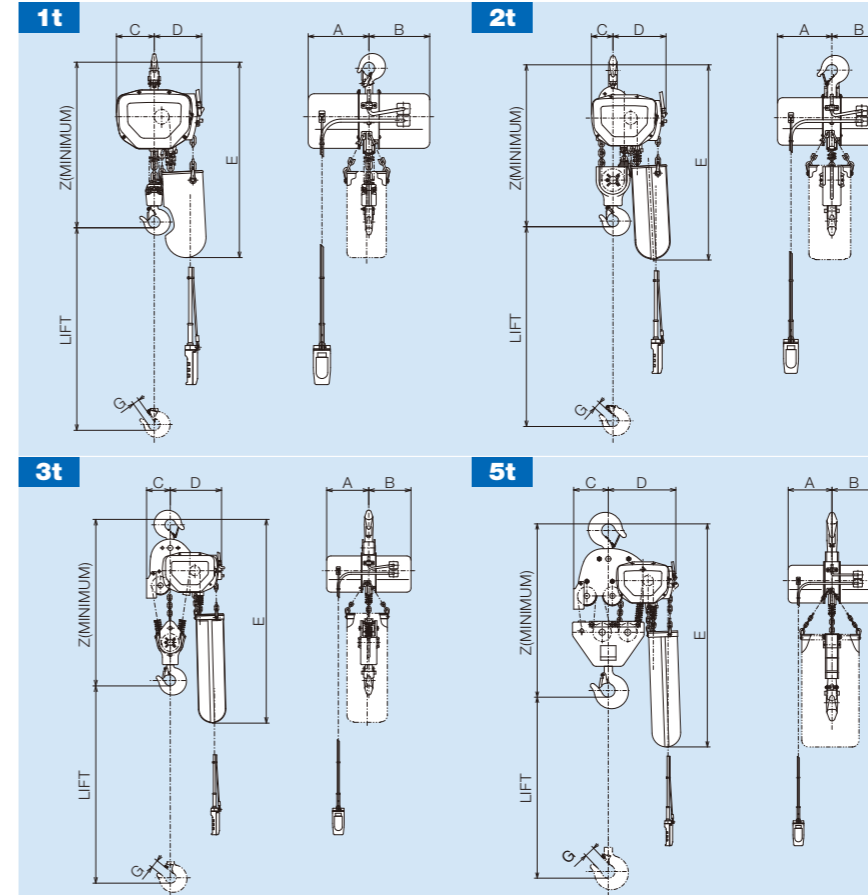

Note
 1) The numbers written in the specifications table and dimensions table may be changed for upgrades, etc.
 2) The dimension drawing shows the state with a load suspended.
 3) The CE version differs slightly from the dimension drawing shape.

Specifications table

SINGLE SPEED (3 PHASE)

Model Name	1S	1SH	2S	2SH	3S	3SH	5S	5SH
Rated Load (kg)	1,000		2,000		3,000		5,000	
Dimensions (mm)	Z	540		665		800		895
	A	216		216		216		216
	B	216		216		216		216
	C	135		90		125		175
	D	170		215		270		340
	D'(CE)	170		215		270		340
	E	680		705	775	835	1,050	1,065
G	23		26		42		48	
Approx. Weight (kg)	37	42	49	59	61	72	88	105

All dimensions and specifications are subject to change without notice.

DUAL SPEED (3 PHASE)

Model Name	1SN	1SNH	2SN	2SNH
Rated Load (kg)	1,000		2,000	
Dimensions (mm)	Z	550		665
	A	216		216
	B	246		246
	C	135		90
	D	170		215
	D'(CE)	170		215
	E	680		705
G	23		26	
Approx. Weight (kg)	42	47	54	64

SINGLE PHASE

Model Name	1S1	1SH1	2S1	2SH1
Rated Load (kg)	1,000		2,000	
Dimensions (mm)	Z	540		665
	A	246		246
	B	246		246
	C	135		90
	D	170		215
	D'(CE)	170		215
	E	680		705
G	23		26	
Approx. Weight (kg)	39	44	51	61

All dimensions and specifications are subject to change without notice.

With motorized trolley-ET

This can be combined with a 4-point or 6-point pushbutton and used as a motorized trolley or overhead traveling crane.

Dimensions

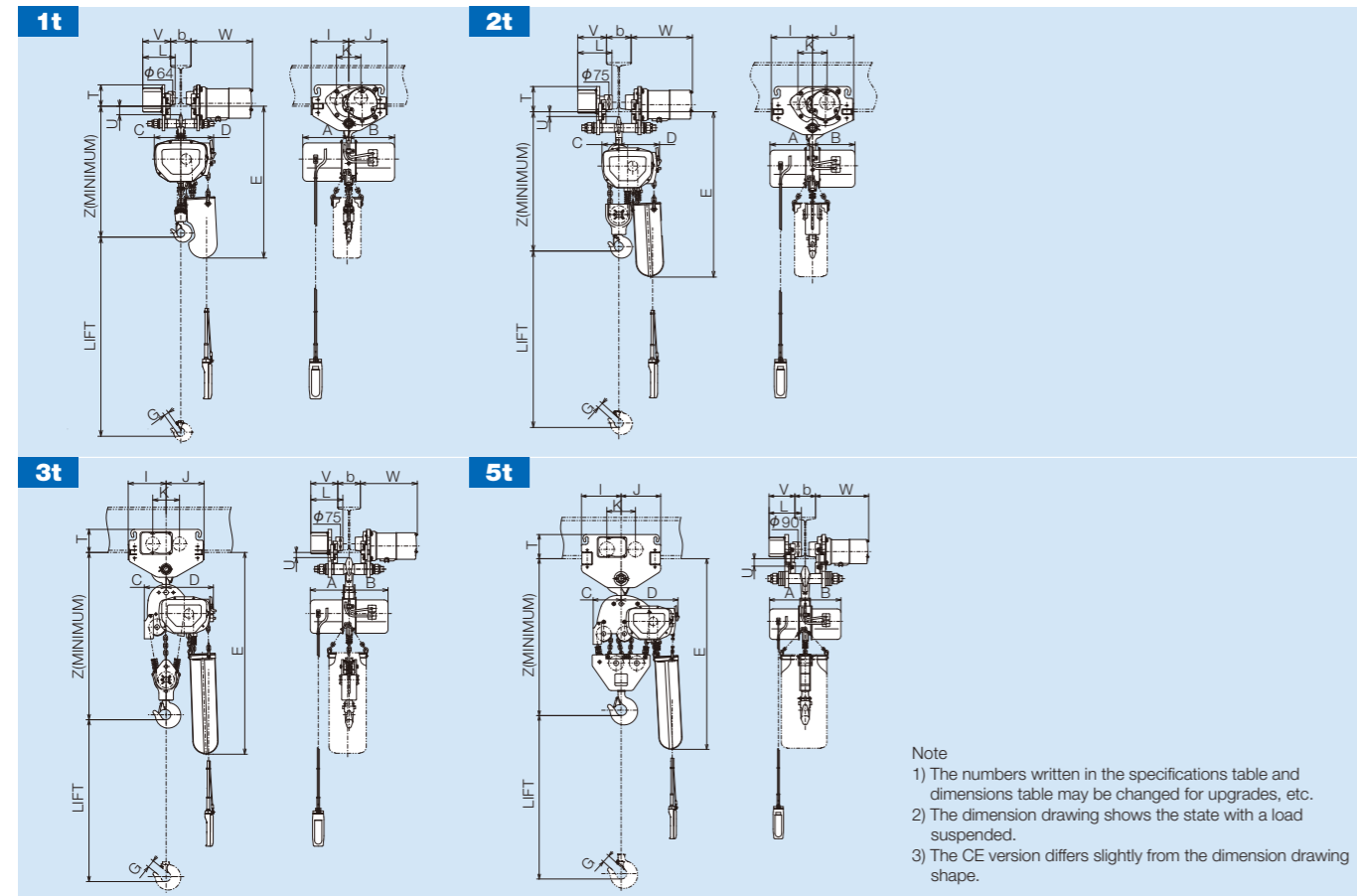

- Note
- 1) The numbers written in the specifications table and dimensions table may be changed for upgrades, etc.
 - 2) The dimension drawing shows the state with a load suspended.
 - 3) The CE version differs slightly from the dimension drawing shape.

Specifications table

Chain Hoist Model Name	1S(H)	1SN(H)	2S(H)	2SN(H)	3S(H)	5S(H)
Trolley Type	1ET		2ET		3ET	5ET
Rated Load (kg)	1,000		2,000		3,000	5,000
Z	610	620	721	721	862	984
A	216	216	216	216	216	216
B	216	246	216	246	216	216
C	135	135	90	90	125	175
D	170	170	215	215	270	340
D'(CE)	170	170	215	215	270	340
E	750	750	770(840)		910(1,125)	1,170(1,200)
G	23	23	26	26	42	48
I	185		210		210	240
J	190		210		210	240
K	120		148		148	173
L	182		200		203	219
T	110		140		140	156
U	38		18		16	34
V	159		172		175	181
W	303		313		316	323
Min.Curve Radius (m)	1.5		1.8		2.0	3.0
Applicable Beam Width b (mm)	75-125		100-150		125-175	125-175
Approx.Weight (kg)	75(80)	80(85)	101(111)	106(116)	121(132)	174(191)

All dimensions and specifications are subject to change without notice.

Motorized trolley specifications table

Series Name	ET series				ST series		
Model Name	1ET	2ET	3ET	5ET	1ST	2ST	3ST
Working Load Limit (kg)	1,000	2,000	3,000	5,000	1,000	2,000	3,000
Traveling Speed (m/min)	10.5(21)				10.5		
	12.5(25)				12.5		
Motor Output (kW)	0.14(0.27)		0.3(0.6)		0.07	0.14	0.2
	0.16(0.32)		0.35(0.7)		0.08	0.16	0.24
Applicable Beam Width b (mm)	75-125	100-150		125-175	75-125	100-150	
Rating	25%ED						

With motorized trolley-ST

This can be combined with a 4-point or 6-point pushbutton and used as a motorized trolley or overhead traveling crane.

Dimensions

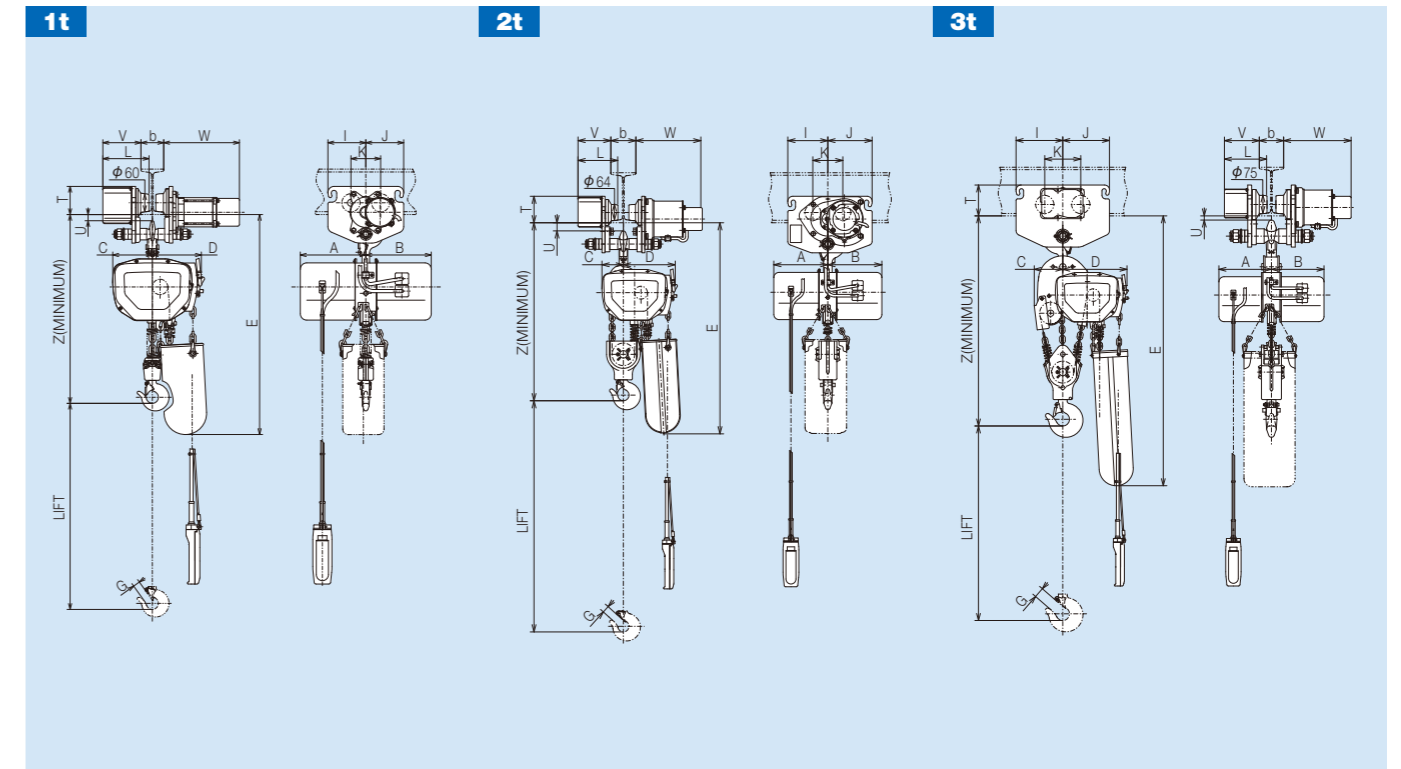

Specifications table

Chain Hoist Model Name	1S(H)	1SN(H)	2S(H)	2SN(H)	3S(H)
Trolley Type	1ST		2ST		3ST
Rated Load (kg)	1,000		2,000		3,000
Z	590	590	719	719	852
A	216	216	216	216	216
B	216	246	216	246	216
C	135	135	90	90	125
D, D'(CE)	170	170	215	215	270
E	730	730	772(842)		900(1,115)
G	23	23	26	26	42
I	125		160		192
J	125		177		192
K	98		120		148
L	156		163		180
T	101		119		140
U	18		19		5
V	130		135		145
W	255		270		280
Min.Curve Radius (m)	1.8		2.5		3.0
Applicable Beam Width b (mm)	75-100		100-150		100-150
Approx.Weight (kg)	60(65)	65(70)	86(96)	91(101)	109(120)

All dimensions and specifications are subject to change without notice.

With chain driven trolley-BC

The electric chain hoist with chain driven trolley is suitable for relatively heavy loads not transported a long distance.

Dimensions

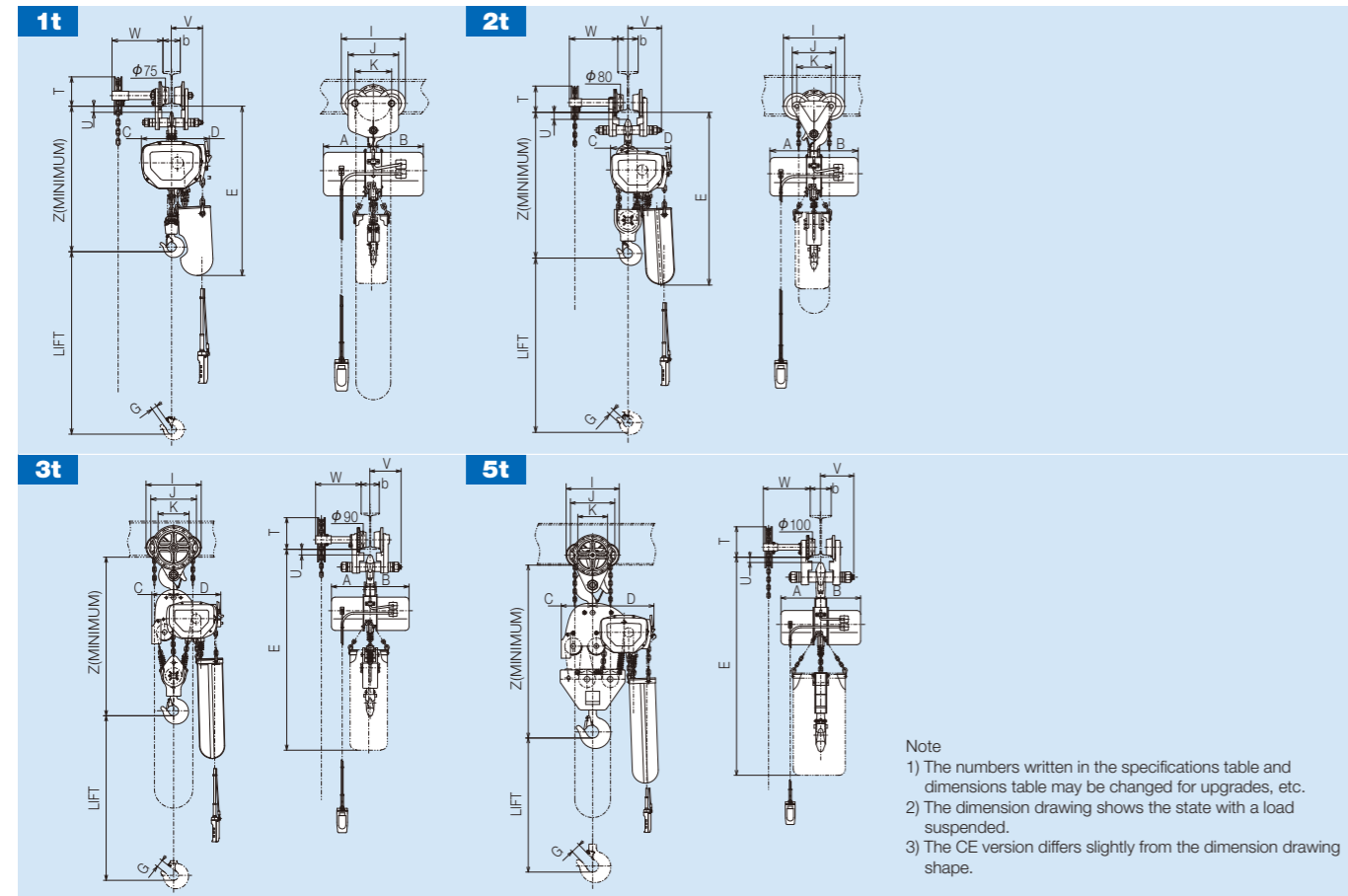

- Note
- 1) The numbers written in the specifications table and dimensions table may be changed for upgrades, etc.
 - 2) The dimension drawing shows the state with a load suspended.
 - 3) The CE version differs slightly from the dimension drawing shape.

Specifications table

Chain Hoist Model Name	1S(H)	1SN(H)	2S(H)	2SN(H)	3SH	5SH	
Trolley type	1BC(H)		2BC(H)		3BCH	5BCH	
Rated Load (kg)	1,000		2,000		3,000	5,000	
Dimensions (mm)	Z	585	585	723	723	866	980
	A	216	216	216	216	216	216
	B	216	246	216	246	216	216
	C	135	135	90	90	125	175
	D	170	170	215	215	270	340
	D'(CE)	170	170	215	215	270	340
	E	740	740	775(845)		1,130	1,190
	G	23	23	26	26	42	48
	I	277		300		306	319
	J	218		213		240	262
	K	158		169		172	177.2
	T	131		143		191	194
	U	23		22		21	30
	V	135		165		173	200
	W	220		236		252	284
Min. Curve Radius (m)	1.2		1.5		1.5	2.4	
Applicable Beam Width b (mm)	75-125		100-150		100-150	125-175	
Approx. Weight (kg)	58(66)	63(71)	73(86)	78(91)	116	161	

With manual driven trolley-BP

The electric chain hoist with manual driven trolley is suitable for relatively light loads transported a short distance.

Dimensions

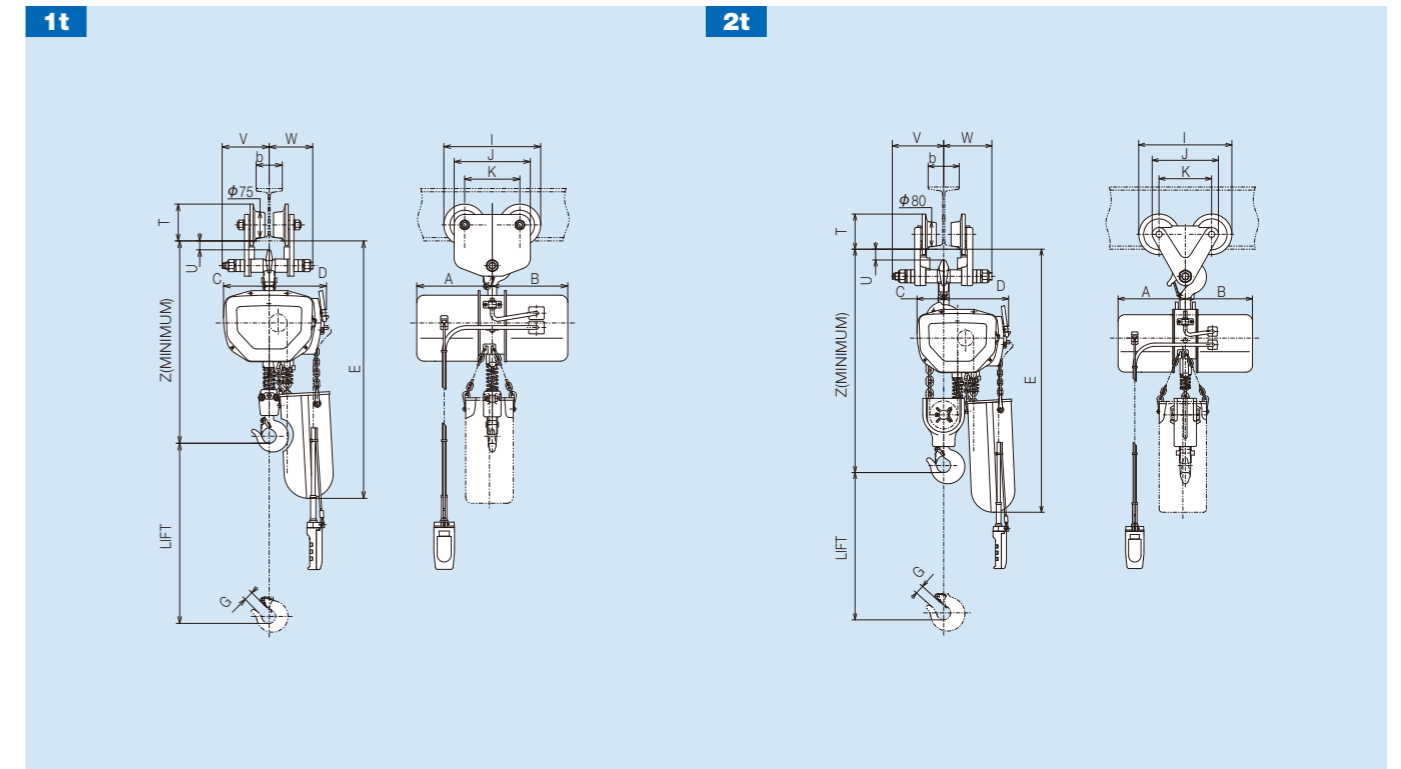

Specifications table

Chain Hoist Model Name	1S(H)	1SN(H)	2S(H)	2SN(H)	
Trolley type	1BP		2BP		
Rated Load (kg)	1,000		2,000		
Dimensions (mm)	Z	595	595	723	723
	A	216	216	216	216
	B	216	246	216	246
	C	135	135	90	90
	D	170	170	215	215
	D'(CE)	170	170	215	215
	E	740	740	775(845)	
	G	23	23	26	26
	I	277		300	
	J	199		213	
	K	139		169	
	T	110		128	
	U	23		22	
	V	135		165	
	W	125		155	
Min. Curve Radius (m)	1.2		1.5		
Applicable Beam Width b (mm)	75-125		100-150		
Approx. Weight (kg)	52(57)	57(62)	66(76)	71(81)	

Chain driven trolley, manual driven trolley specifications table

Classification	Chain driven trolley				Manual driven trolley	
Model Name	1BC(H)	2BC(H)	3BCH	5BCH	1BP	2BP
Working Load Limit (kg)	1,000	2,000	3,000	5,000	1,000	2,000
Standard Lift (m)	3(6)	3(6)	6	6	—	—
Min. Curve Radius (m)	1.2	1.5	1.5	2.4	1.2	1.5
Applicable Beam Width b (mm)	75-125	100-150		125-175	75-125	100-150

For a crane that uses a chain or manual driven trolley for transverse movement and an electric motor for travel, please purchase a 4PB(H)-C, 4PBN(H)-C type wiring unit (See page 23).

F series

Electric chain hoist

Suspension type

Single speed model

Dual speed model



Specifications table

SINGLE SPEED (3 PHASE)

F(H)		1F(H)	2F(H)	3F(H)	5F(H)	10FH	15FH	20FH
Model Name	(kg)	1,000	2,000	3,000	5,000	10,000	15,000	20,000
Rated Load	(kg)	1,000	2,000	3,000	5,000	10,000	15,000	20,000
Standard Lift	(m)	3(6)			6			
Hoisting Speed (m/min)	50Hz	7.1	6.8	4.1	2.8	2.8	1.8	1.4
	60Hz	8.5	8.2	4.9	3.3	3.3	2.2	1.6
Motor Output (kW)	50Hz	1.3	2.4		2.4×2			
	60Hz	1.6	2.9		2.9×2			
Link Chain	Dia. (mm)	φ 7.1		φ 10				
	No. of Falls	1	1	2	3	4	6	8
Rating		30% ED						
Power Cord Length		5m						

DUAL SPEED (3 PHASE)

FN(H)		2FN(H)	3FN(H)	5FN(H)	10FNH	15FNH
Model Name	(kg)	2,000	3,000	5,000	10,000	15,000
Rated Load	(kg)	2,000	3,000	5,000	10,000	15,000
Standard Lift	(m)	3(6)		6		
Hoisting Speed (m/min)	50Hz	6.8/1.7	4.0/1.0	2.8/0.7	2.8/0.7	1.8/0.45
	60Hz	8.2/2.1	4.8/1.2	3.3/0.8	3.3/0.8	2.2/0.55
Motor Output (kW)	50Hz	2.4/0.6		2.4/0.6×2		
	60Hz	2.9/0.7		2.9/0.7×2		
Link Chain	Dia. (mm)	φ 10				
	No. of Falls	1	2	3	4	6
Rating		20% ED				
Power Cord Length		5m				

All dimensions and specifications are subject to change without notice.

Suspension type

Fseries

Dimensions

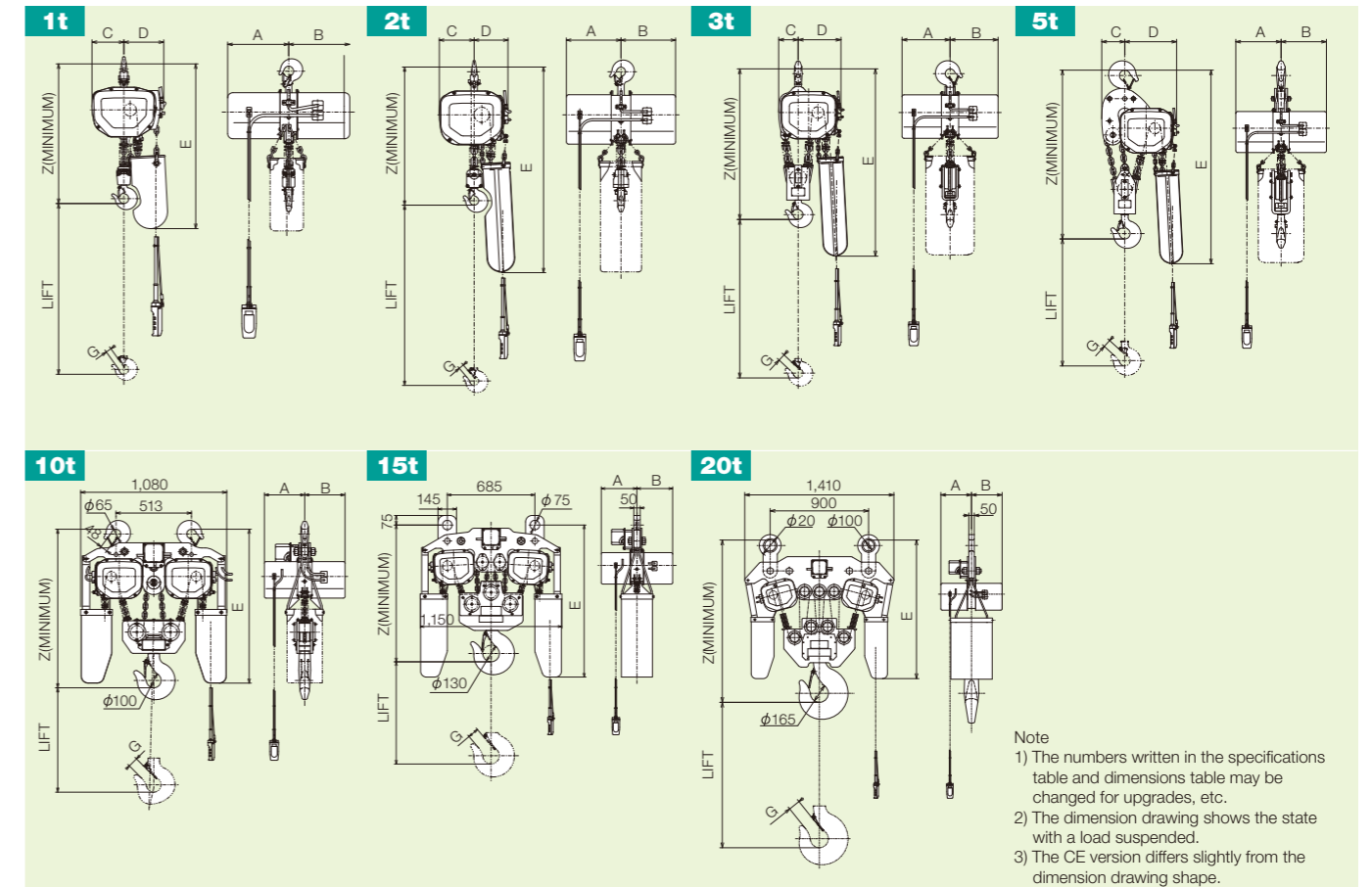

Note
 1) The numbers written in the specifications table and dimensions table may be changed for upgrades, etc.
 2) The dimension drawing shows the state with a load suspended.
 3) The CE version differs slightly from the dimension drawing shape.

Specifications table

SINGLE SPEED (3 PHASE)

Model Name	1F	1FH	2F	2FH	3F	3FH	5F	5FH	10FH	15FH	20FH
Rated Load	(kg)	1,000	2,000	3,000	5,000	10,000	15,000	20,000			
Dimensions	Z	540	670	830	1,020	1,060	1,235	1,440			
	A	250	280	280	280	280	280	280			
	B	250	280	280	280	280	280	280			
	C	135	175	120	145	—	—	—			
	D	170	170	245	330	—	—	—			
	E	680	845	1,060	1,090	1,100	1,295	1,305	1,040	1,280	1,400
	G	23	26	42	48	68	86	108			
Approx. Weight	(kg)	42	47	81	87	103	113	140	152	330	490

All dimensions and specifications are subject to change without notice.

DUAL SPEED (3 PHASE)

Model Name	2FN	2FNH	3FN	3FNH	5FN	5FNH	10FNH	15FNH	
Rated Load	(kg)	2,000	3,000	5,000	10,000	15,000			
Dimensions	Z	680	830	1,020	1,060	1,235			
	A	280	280	280	280	280			
	B	330	330	330	330	330			
	C	175	120	145	—	—			
	D	170	245	330	—	—			
	E	845	1,060	1,090	1,100	1,295	1,305	1,040	1,280
	G	26	42	48	68	86			
Approx. Weight	(kg)	96	102	116	128	146	167	360	

All dimensions and specifications are subject to change without notice.

Outline

L series

S series

F series

Others

With motorized trolley-ET

This can be combined with a 4-point or 6-point pushbutton and used as a motorized trolley or overhead traveling crane.

Dimensions

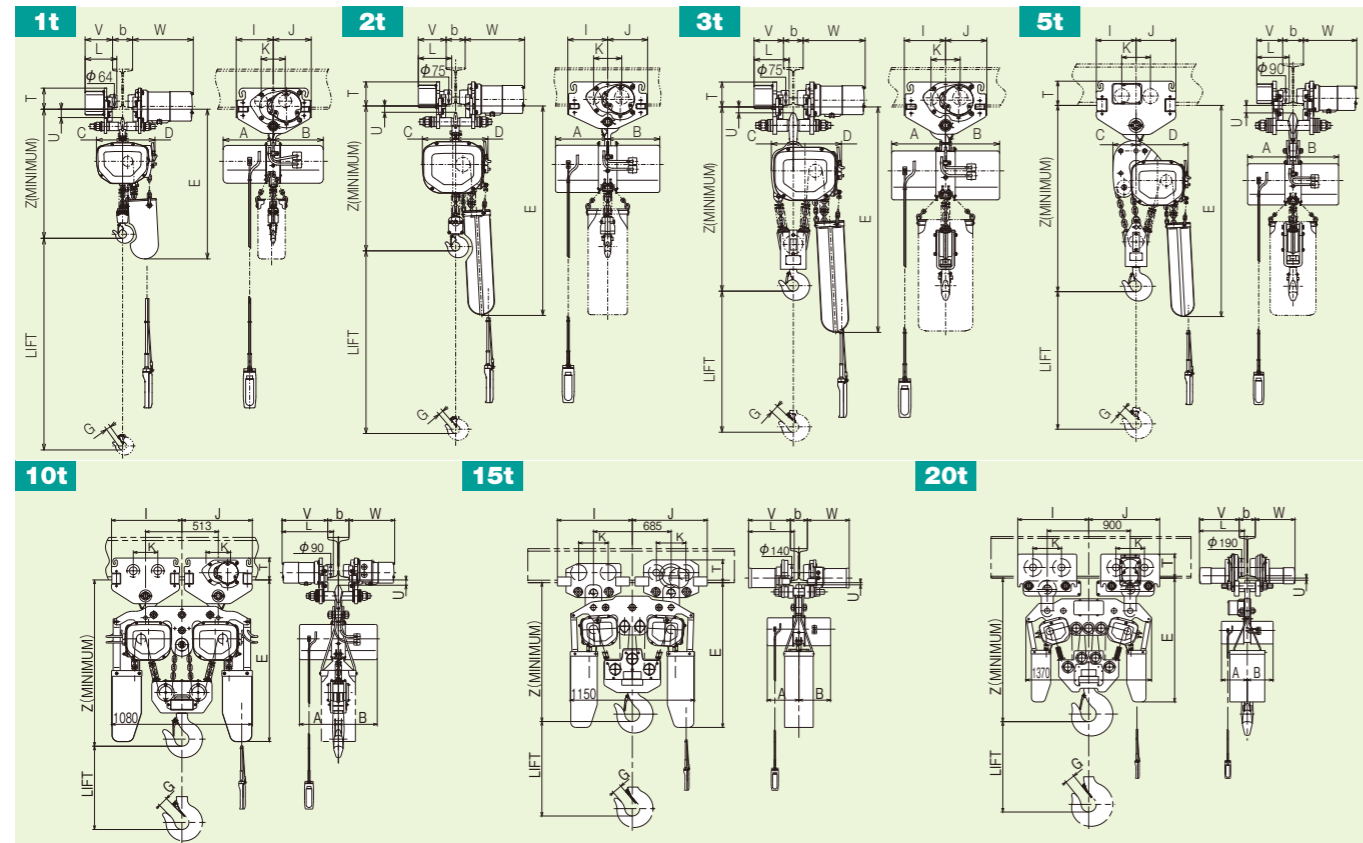

Note
 1) The numbers written in the specifications table and dimensions table may be changed for upgrades, etc.
 2) The dimension drawing shows the state with a load suspended.
 3) The CE version differs slightly from the dimension drawing shape.

Specifications table

Chain Hoist Model Name	1F(H)	2F(H)	2FN(H)	3F(H)	3FN(H)	5F(H)	5FN(H)	10FH	10FNH	15FH	15FNH	20FH					
Trolley Type	1ET	2ET	3ET	5ET	5ET×2	7.5ET×2	10ET×2										
Rated Load (kg)	1,000	2,000	3,000	5,000	10,000	15,000	20,000										
Z	610	731	736	892	892	1,112	1,112	1,150	1,152	1,150	1,152	1,210	1,212	1,210	1,212	1,520	1,515
A	250	280	280	280	280	280	280	280	280	280	280	280	280	280	280	280	280
B	250	280	330	280	330	280	330	280	330	280	330	280	330	280	330	280	330
C	135	185	185	120	120	145	145	—	—	—	—	—	—	—	—	—	—
D	170	170	170	245	245	330	330	—	—	—	—	—	—	—	—	—	—
E	750	945(1,125)	1,130(1,185)	1,410	1,410	1,130	1,130	1,265	1,265	1,265	1,265	1,375	1,375	1,375	1,375	1,375	1,375
G	23	26	26	42	42	48	48	68	68	86	86	108	108	108	108	108	108
I	185	210	210	240	240	500	500	663	663	663	663	770	770	770	770	770	770
J	190	210	210	240	240	500	500	663	663	663	663	770	770	770	770	770	770
K	120	148	148	173	173	173	173	260	260	260	260	309	309	309	309	309	309
L	182	200	203	219	219	362	362	434	434	434	434	511	511	511	511	511	511
T	110	140	140	156	156	158	156	158	156	205	203	205	203	205	203	280	285
U	38	18	16	34	34	32	34	32	34	15	17	15	17	23	18	23	18
V	159	172	175	181	181	323	323	401	401	401	401	455	455	455	455	455	455
W	303	313	316	323	323	323	323	401	401	401	401	455	455	455	455	455	455
Min. Curve Radius (m)	1.5	1.8	2.0	3.0	3.0	5.0	5.0	5.0	5.0	5.0	5.0	Straight	Straight	Straight	Straight	Straight	Straight
Applicable Beam Width b (mm)	75-125	100-150	100-150	125-175	125-175	150	175	150	175	150	175	150	175	150	175	175	190
Approx. Weight (kg)	80(85)	132(139)	147(154)	161(175)	176(190)	217(238)	232(253)	502	532	860	890	1,490	1,490	1,490	1,490	1,490	1,490

All dimensions and specifications are subject to change without notice.

With motorized trolley-ST

This can be combined with a 4-point or 6-point pushbutton and used as a motorized trolley or overhead traveling crane.

Dimensions

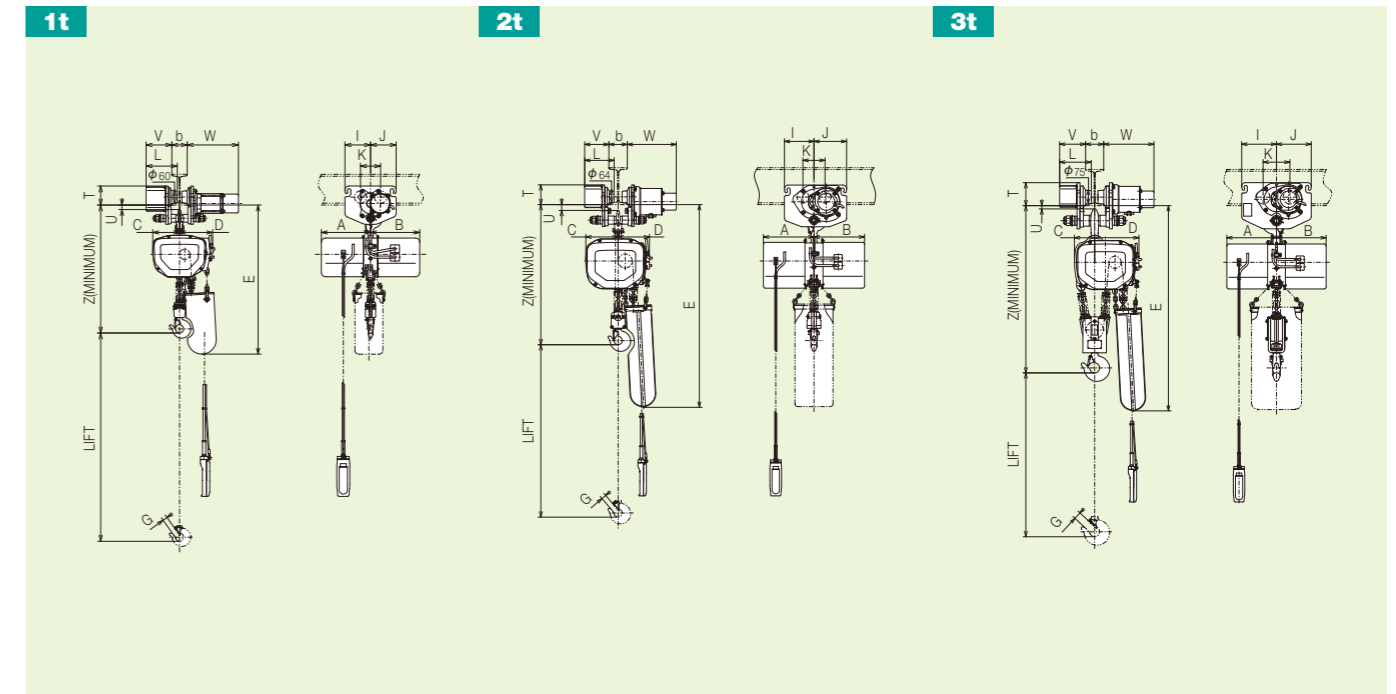

Specifications table

Chain Hoist Model Name	1F(H)	2F(H)	2FN(H)	3F(H)	3FN(H)
Trolley Type	1ST	2ST	2ST	3ST	3ST
Rated Load (kg)	1,000	2,000	2,000	3,000	3,000
Z	582	715	715	872	872
A	250	280	280	280	280
B	250	280	330	280	330
C	135	185	185	120	120
D	170	170	170	245	245
E	725	935(1,115)	935(1,115)	1,110(1,165)	1,110(1,165)
G	23	26	26	42	42
I	125	160	160	192	192
J	125	177	177	192	192
K	98	120	120	148	148
L	156	163	163	180	180
T	101	119	119	140	140
U	18	19	19	5	5
V	130	135	135	145	145
W	255	270	270	280	280
Min. Curve Radius (m)	1.8	2.5	2.5	3.0	3.0
Applicable Beam Width b (mm)	75-125	100-150	100-150	100-150	100-150
Approx. Weight (kg)	66(71)	117(124)	132(139)	140(161)	155(176)

Motorized trolley specifications table

Series Name	ET series							ST series			
Model Name	1ET	2ET	3ET	5ET	5ET×2	7.5ET×2	10ET×2	1ST	2ST	3ST	
Working Load Limit (kg)	1,000	2,000	3,000	5,000	10,000	15,000	20,000	1,000	2,000	3,000	
Travelling Speed (m/min)	10.5(21)			10.5			14	10.5			
	60Hz			12.5(25)			17	12.5			
Motor Output (kW)	0.14(0.27)		0.3(0.6)		0.3×2		0.35×2		0.7×2		
	60Hz		0.35(0.7)		0.35×2		0.42×2		0.84×2		
Applicable Beam Width b (mm)	75-125		100-150		125-175		150, 175		175, 190		
Rating	25%ED							40%ED		25%ED	

All dimensions and specifications are subject to change without notice.

With chain driven trolley-BC

The electric chain hoist with chain driven trolley is suitable for relatively heavy loads not transported a long distance.

Dimensions

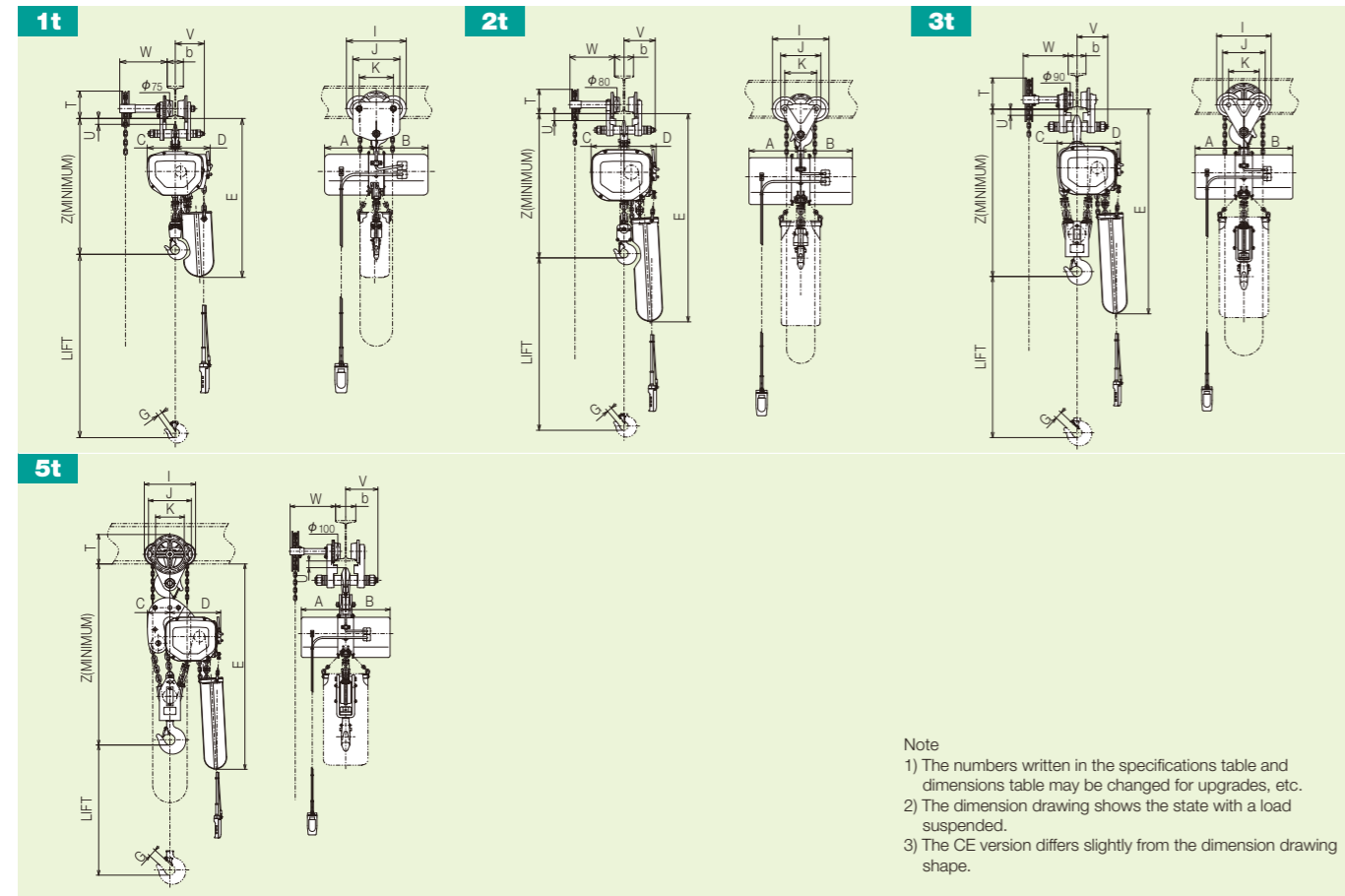

- Note
- 1) The numbers written in the specifications table and dimensions table may be changed for upgrades, etc.
 - 2) The dimension drawing shows the state with a load suspended.
 - 3) The CE version differs slightly from the dimension drawing shape.

Specifications table

Chain Hoist Model Name	1F(H)	2F(H)	2FN(H)	3FH	3FNH	5FH	5FNH
Trolley type	1BC(H)	2BC(H)		3BCH		5BCH	
Rated Load (kg)	1,000	2,000	2,000	3,000		5,000	
Dimensions (mm)	Z	595	717	717	896	896	1,105
	A	250	280	280	280	280	280
	B	250	280	330	280	330	280
	C	135	175	175	120	120	145
	D	170	170	170	245	245	330
	E	740	1,130	1,130	1,180	1,180	1,405
	G	23	26	26	42	42	48
	I	277	300		306		319
	J	218	213		240		262
	K	158	169		172		177.2
	L	—	—		—		—
	T	131	143		191		194
	U	23	22		21		30
	V	135	165		173		200
W	220	236		252		284	
Min. Curve Radius (m)	1.2	1.5		1.5		2.4	
Applicable Beam Width b (mm)	75–125	100–150		100–150		125–175	
Approx. Weight (kg)	63(71)	104(114)	120(129)	157	170	198	223

With manual driven trolley-BP

The electric chain hoist with manual driven trolley is suitable for relatively light loads transported a short distance.

Dimensions

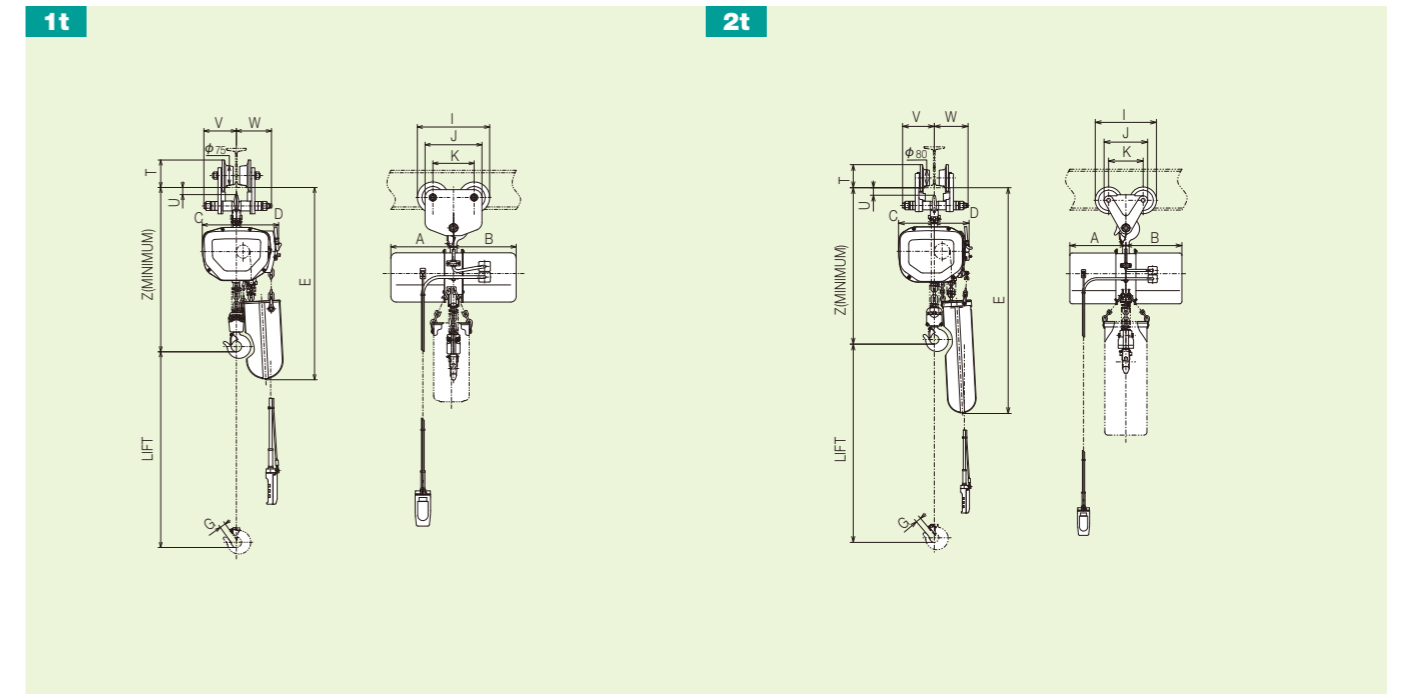

Specifications table

Chain Hoist Model Name	1F(H)	2F(H)	2FN(H)	
Trolley type	1BP	2BP		
Rated Load (kg)	1,000	2,000		
Dimensions (mm)	Z	595	717	717
	A	250	280	280
	B	250	280	330
	C	135	175	175
	D	170	170	170
	E	740	1,130	1,130
	G	23	26	26
	I	277	300	
	J	218	213	
	K	158	169	
	L	—	—	
	T	110	128	
	U	23	22	
	V	125	155	
W	135	165		
Min. Curve Radius (m)	1.2	1.5		
Applicable Beam Width b (mm)	75–125	100–150		
Approx. Weight (kg)	57(62)	97(104)	113(119)	

Chain driven trolley, manual driven trolley specifications table

Classification	Chain driven trolley				Manual driven trolley	
	1BC(H)	2BC(H)	3BCH	5BCH	1BP	2BP
Model Name	1,000	2,000	3,000	5,000	1,000	2,000
Working Load Limit (kg)	1,000	2,000	3,000	5,000	1,000	2,000
Standard Lift (m)	3(6)	3(6)	6	6	—	—
Min. Curve Radius (m)	1.2	1.5	1.5	2.4	1.2	1.5
Applicable Beam Width b (mm)	75–125	100–150		125–175	75–125	100–150

For a crane that uses a chain or manual driven trolley for transverse movement and an electric motor for travel, please purchase a 4PB(H)-C, 4PBN(H)-C type wiring unit (See page 23).

4-point pushbutton crane wiring unit

- This is a wiring unit for connecting to the crane electro-magnetic switch and the hoist main unit.
- Connection can be done simply by just attaching to the hoist main unit.
- A unique HITACHI operation cable with a single protective wire provides excellent operability and durability.
- The pushbutton is made of drip-proof hardened plastic.
- The pushbutton cable employs a one-touch outlet to allow it to be connected easily.

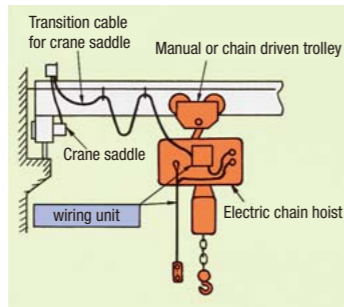

Specifications table

The product is a wiring unit that combines an electric chain hoist with an crane saddle for use with manual traverse (manual or chain driven trolley) and motorized travel 4-point pushbutton cranes.

For single speed models

Model Name	4PB-C	4PBH-C
Lift	3m	6m
Approx. Weight	3kg	3.5kg

For double speed models

Model Name	4PBN-C	4PBNH-C
Lift	3m	6m
Approx. Weight	3.5kg	4kg

Electro-magnetic switch unit with crane case

- This is the electro-magnetic switch unit with a case for girder operation (24V) for when a HITACHI electric chain hoist (with motorized trolley) is used in a crane girder system. (Applicable up to HITACHI crane saddle TLU5-56 and TH5-56)

- Install in a freely selected location of the girder system, and the transition cables for girder and trolley, and the power cable are connected to the terminal block.

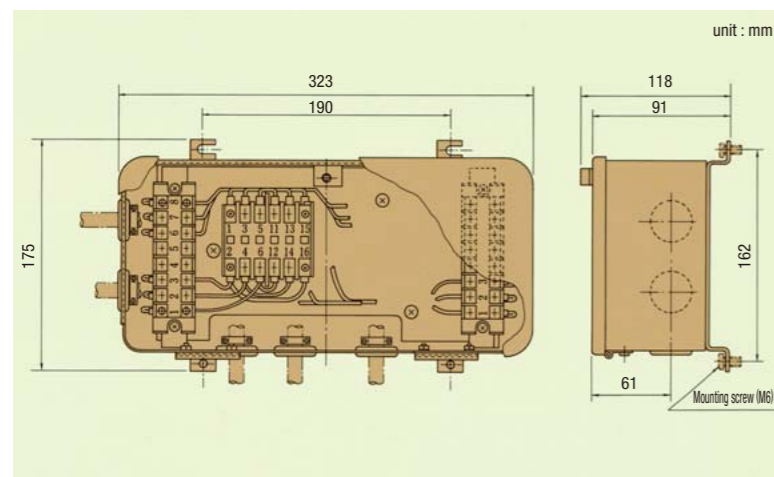
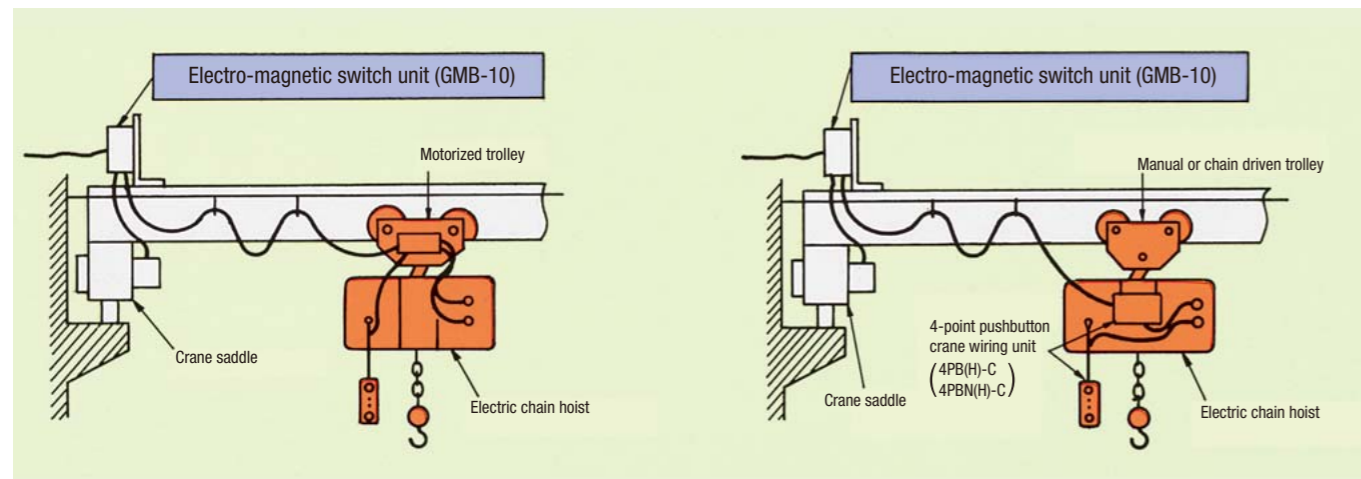

Specifications table

Model Name	GMB-10	
Electro-magnetic Contactor	Type	HMU-12
	Control Voltage	24V
	Current Capacity	10A
Approx. Weight	4kg	

Twin hook type electric chain hoist

The HITACHI twin hook type electric chain hoist is a two-chain, two-hook type with two chain hoists in the same sprocket axis. Since there is 1 chain hoist drive, the load is kept level during hoisting. This is optimal for long items that must be hoisted from 2 points and cargo that must be kept level.

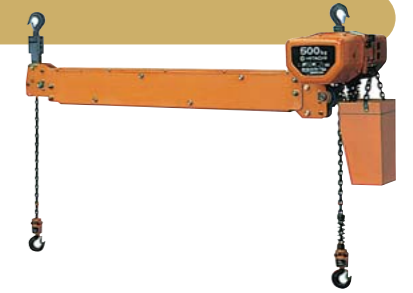

Basic specifications table

Model (main unit)	1/4SHT	1/2SHT	1SHT	1FHT	2FHT
Rated Load	125kg×2	250kg×2	500kg×2	500kg×2	1000kg×2
Standard Lift (m)	6				
Hoisting Speed (m/min)	50Hz	7.1	4.6	7.1	6.8
	60Hz	11	8.5	5.5	8.5
Traveling Speed (m/min)	10.5				
	12.5				
Hoisting Motor (kW)	50Hz	0.4	0.65	0.8	1.3
	60Hz	0.5	0.8	1.0	1.6
Traveling Motor (kW)	2				
	0.14				
Link Chain (dia./falls)	4				
	φ7.1×2				
				φ10×2	

* A load must always be applied to the lower hook P side, so please inform HITACHI when a original sling will not be used.

Dimensions

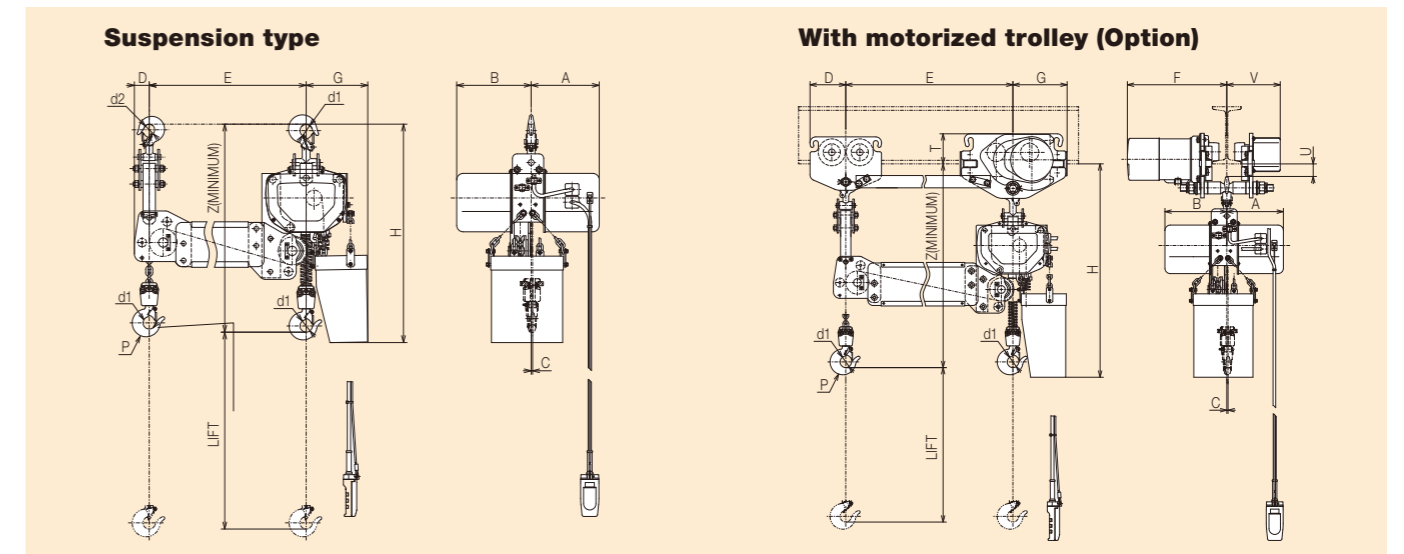

Specifications table

Chain Hoist Model Name	1/4SHT	1/2SHT	1SHT	1FHT	2FHT	
Trolley Type	1ET					
Dimensions (mm)	A	212		246	286	
	B	252		286	339	
	C	5		5	6	
	D	125(48)		125(48)	125(61)	
	φ d ₁	40		40	45	
	φ d ₂	35.5		35.5	40	
	E	500-2,000(50 Interval) The actual dimensions differ slightly.				
	F	341	353	366	341	353
	G	190(170)			190(170)	
	V	174	187	199	174	187
	T	110				140
	U	38				18
	With Motorized Trolley	H	837	836	834	837
Suspension	Z	744	743	741	744	
	H	765			925	
	Z	672			810	
Applicable Beam Width (mm)	75-125			75-125		
				100-150		

* The suspension type is shown in parentheses ().
* Only the straight rail is applicable to the trolley.

Network

Hitachi Industrial Equipment Systems Co., Ltd. meets customers' needs through the total network which can supply speedy design, production, sales, service and engineering for industrial equipment and systems.

Global Sales Network



Information in this brochure is subject to change without notice.

Hitachi Industrial Equipment Systems Co., Ltd.

For further information, please contact your nearest sales representative.



Registration number: JACO-EC99J2009
Registration date: July 22, 1996

Hitachi Industrial Equipment Systems Co., Ltd. (Taga Administrative division) obtained ISO 14001 certification, an international standard for environmental management systems.



Registration number: JQA-QMA 12087
Registration date: April 1, 2005

Hitachi Industrial Equipment Systems Co., Ltd. (Taga Administrative division) obtained international standard ISO 9001 certification for the quality assurance of the hoist motor block contained in this brochure.

